

VAr-Min

Intelligent Capacitor Control Operating Manual

Valquest Systems, Inc.



Copyright

Copyright© 2015 Valquest Systems, Inc.

All rights reserved. No part of this publication may be reproduced, stored in a retrieval system, or transmitted, in any form or by any means - electronic, mechanical, photocopying, recording, or otherwise - without prior written permission of **Valquest Systems, Inc.**

Valquest Systems, Inc. provides this manual “as is”, without warranty of any kind either expressed or implied. **Valquest Systems, Inc.** may make changes and/or improvements in this manual at any time and without notice.

Although **Valquest Systems, Inc.** has gone to great effort to verify the integrity of the information herein, this publication could contain technical inaccuracies or typographical errors. Changes are periodically made to the information contained herein. These changes will be incorporated in new editions of this publication.

Table of Contents

1 Introduction

2 Smart Switching

- 2.1 Absolute Knowledge of Switch Position
- 2.2 Anticipated Voltage Switching
- 2.3 Delta Voltage based Op Delay
- 2.4 Blown Capacitor Fuse Detection
- 2.5 Voltage and Frequency Relaying
- 2.6 Fast DC Tripping

3 Installation

- 3.1 Capacitor Rack
- 3.2 Line Post Current Sensor
- 3.3 Fuses
- 3.4 Cable Connections
- 3.5 Grounding
- 3.6 Dos and Don'ts

4 Electrical Measurements

- 4.1 Voltage
- 4.2 Current
- 4.3 Frequency
- 4.4 Calculations
- 4.5 Switch Position

5 Data Storage

- 5.1 Operation History
- 5.2 Trending
- 5.3 Delta Voltages

6 Operating Modes

- 6.1 Automatic
- 6.2 Remote
- 6.3 Manual

7 Front Panel

- 7.1 Switches and LEDs
- 7.2 Display and Knob
- 7.3 USB Port
- 7.4 Test Jacks
- 7.5 Fuses
- 7.6 SCADA Communications Access Panel

8 Capacitor Switch Control

- 8.1 Manual
- 8.2 Automatic
- 8.3 Fast Voltage and Frequency Tripping
- 8.4 Control Algorithm
- 8.5 Hardware Configuration Settings
- 8.6 Control Configuration Wizard

9 Front Panel Display Description

- 9.1 Splash Screen
- 9.2 Real Time Information
- 9.3 Config Menu
- 9.4 Display Screen Flow Diagrams

10 Communications

- 10.1 RS232 (Optically Isolated)
- 10.2 Fiber Optic
- 10.3 Ethernet

11 Appendix

- 11.1 Meter Base Configurations
- 11.2 Figure 1 - VAr-Min Pole Configuration
- 11.3 Figure 2 - VAr-Min Pole Grounding
- 11.4 Modbus Registers
- 11.5 DNP 3.0 Data Dictionary

1. Introduction

Valquest Systems, Inc. offers the newest state-of-the-art capacitor control: **VAr-Min™**. This capacitor control model incorporates proven microcontroller technology, USB, Serial, Fiber and Ethernet ports for communication, and industry-standard meter base connectors encased in durable polycarbonate enclosures.

By implementing efficient hardware design techniques combined with user-defined or wizard generated control algorithms, real-time monitoring and capacitor-bank switching capabilities are possible. Each capacitor control samples analog current and voltage waveforms and converts each signal into digital format. An embedded software algorithm calculates in real-time the voltage, current, watts, VARs, phase angle and power factor. A capacitor switching algorithm, pre-programmed by the user, uses these calculations and other variables to control the on/off capacitor bank switching capabilities. This design also allows for historical data recording up to 320 days.

The VAr-Min Companion Software furnished with each capacitor control system is easy to use yet powerful enough to provide detailed information in report or graphical formats. This information can be directed to your computer screen, printed, or stored in standard spreadsheet formats.

Both recording parameters and the report generators can be configured for short-term or long-term data recording modes. Multiple data files are supported for long term historical data analysis. The data analyzed is presented as tabular records or graphical waveforms.

Thank you for your purchase of this capacitor control unit. It is an investment which will pay for itself in a short time by reducing power delivery costs and giving you the information you need to make your system more efficient.

This manual is intended to give you the information you need to install and operate each type of capacitor control unit and the reporting software. However, there may be times that you need to contact us to discuss a unique monitoring environment. We are a service oriented company, and we welcome any questions and suggestions you may have. Please feel free to contact us at the following address:

Valquest Systems
351 S. Sherman, Suite 100
Richardson, Texas 75081
Phone: 972-234-2954
Fax: 972-238-9501

2. Smart Switching

Smart-Switching is incorporated in the VAR-Min Automatic Capacitor Control. It involves the combination of six separate revolutionary features:

2.1. Absolute Knowledge of Switch Position

The VAR-Min knows the position of the cap bank switches at all times regardless of any (or lack of any) previous operating history. It accomplishes this using Close and Trip Circuit Monitoring.

The result is that switching decisions are always made based on accurate information regarding the energized status of the capacitor bank. The switch position detection possibilities are:

- All switches open
- All switches closed
- Switches not all in the same position – possibly cause by switch malfunction
- Control cable unplugged – or damaged cable

2.2. Anticipated Voltage Switching

The VAR-Min continuously learns with each close operation and with each trip operation how much the line voltage increases when the capacitor bank is switched on and how much the voltage decreases when the bank is switched off.

This is advantageous in that the user does not need to try to predict how much voltage variation to program into the control algorithm. Also, the control will modify its settings as line and load conditions change. This feature can be disabled.

2.3. Delta Voltage based Op Delay

With the information from the Anticipated Voltage Switching feature, the Operation Delay Timing can be modified based on the absolute value of the change in voltage after switching.

This allows the controls on a feeder with more delta voltage to operate faster.

2.4. Blown Capacitor Fuse Detection

Utilizing either a CT in the neutral connection of a grounded wye cap bank or a transformer from common to ground of an un-grounded wye bank the VAR-Min can sense a blown fuse condition.

At the users discretion a blown fuse can:

- Be reported via SCADA
- Open the capacitor switches

2.5. Voltage and Frequency Relaying

The VAR-Min has a special Fast Trip feature for when voltage or frequency go out of tolerance. This Fast Trip function will take the capacitors off line much faster than the Normal Open function which is usually based on kVAR, Temperature, Time, Voltage etc.

This is intended to protect both the capacitors and load equipment from dangerous electrical conditions which can occur when an up-line breaker opens on a reactively loaded circuit.

2.6. Fast DC Tripping

This is a VAR-Min feature which allows extremely fast de-energization of the capacitor bank. It also allows opening the switches after loss of AC voltage.

For up to 30 seconds after loss of AC voltage, the control remains active and the bank can still be opened. Solenoid operated switches are required for the feature.

3. Installation

Proper Installation is important for reliable and accurate performance. Please especially observe the Dos and Don'ts section..

3.1. Capacitor Rack

The Capacitor Rack usually holds the following components:

- Capacitors – 3 or 6 depending on bank size
- Switches – 3
- Transformer
- Junction Box
- Neutral CT / PT (Optional)

These should all be mounted before energizing the bank.

3.2. Line Post Current Sensor

The LPCS provides current information to the VAR-Min. It is mounted in place of one of the pin insulators. It should be mounted on the phase that the transformer is connected to.

3.3. Fuses

Each capacitor switch should have its own fuse. Fuses should be sized appropriately for the bank kVAr and line voltage.

In addition the transformer should have its own fuse. This fuse can be quite low amperage since the load on the transformer is very small..

3.4. Cable Connections

The Junction Box will have cables coming out of it that connect to each of the switches, to the transformer, to the LPCS, to the Neutral sensing CT or PT (if used), and down to the VAR-Min control.

3.5. Grounding

3.5.1. The following components should be grounded at rack level

- The distribution Neutral conductor
- The rack itself
- The transformer
- The ground pin in the junction box
- The base of the LPCS
- The capacitor neutral (if it is a grounded wye)
- The Ground Rod wire

3.5.2. Ground Rod Wire

- The Ground Rod wire (usually #6 gauge) comes down the pole from the Neutral to a ground rod
- Never connect anything to this wire except the distribution Neutral Conductor and the ground rod.
- Do not connect any part of the VAR-Min or its meter base to this wire.

3.6. Dos and Don'ts

3.6.1. VAr-Min Neutral connection

- Use the Neutral conductor in the control cable to connect the VAr-Min to Neutral and Ground (the Neutral should be connected to the Ground Rod wire at pole top.
- DO NOT connect any part of the VAr-Min or its meter base to this wire to the Ground Rod wire.

3.6.2. Capacitor Switches

- Use capacitor switches that have voltage ratings appropriate for the line voltage.
- DO NOT use 15kV switches on a 25kV / 14.4kV system even if it is a grounded wye. Various fault conditions can cause over-voltage conditions which will damage the switches

3.6.3. Fuses

- Use a separate fuse for the transformer.
- DO NOT connect the transformer to one of the fused capacitor switch wires.

3.6.4. Phasing

- Put the LPCS on the same phase as the transformer if the transformer has a phase to neutral primary.
- Put the LPCS on the phase that the transformer is not connected to if the transformer has a phase to phase primary.
- DO NOT put the LPCS on some other randomly picked or convenient phase.

4. Electrical Measurements

The VAr-Min uses state of the art circuitry and firmware to make precise electrical measurements. These electrical quantities are necessary for effective switched bank capacitor control.

4.1. Voltage

- Voltage is measured from the secondary winding of the single phase control transformer on the capacitor rack.
- The RMS value is calculated directly from the voltage waveform using proprietary algorithms embedded in the microprocessor.
- An onboard jumper allows selection of either 120 or 240 VAC as the voltage source.
- A front panel setting allows configuration of the primary voltage.

4.2. Current

- Current is measured from the Line Post Current Sensor (LPCS).
- The RMS value is calculated directly from the current waveform using proprietary algorithms embedded in the microprocessor.
- A front-end gain setting is accessible from the front panel which allows adjustment of current range.

4.3. Frequency

- Line frequency is measured from the secondary winding of the single phase control transformer on the capacitor rack.

4.4. Calculations

- KW is calculated from the current and voltage waveforms proprietary algorithms embedded in the microprocessor.
- KVA is calculated from the current and voltage waveforms proprietary algorithms embedded in the microprocessor.
- KW and kVA calculations are single phase calculations multiplied by three so as to estimate three phase values.
- KVA is calculated directly from kW and kVA.
- Phase Angle is calculated from kW and kVA.
- Power Factor is calculated from kW and kVA.

4.5. Switch Position

- Switch position is monitored through both the Close and Open control wires in the umbilical cable.
- Switch position is important for safety reasons and for reliable capacitor control.
- The following switch positions are possible:
 - Closed – all three switches closed
 - Open – all three switches open
 - Switch Malfunction – both open and closed switch positions detected
 - Broken Cable – neither open nor closed switch position detected

5. Data Storage

Several types of data are stored in non-volatile memory. These can help the operator as well as the unit itself make better decisions about operating parameters and even capacitor bank placement.

5.1. Operation History

- An operation event is added any time the VAr-Min detects a switch position change.
- An operation event is added when the VAr-Min has initiated a control operation and the switch position does not change within 10 seconds after the end of the operation.
- Each event contains the following information:
 - Event
 - Cause
 - Date
 - Time
- The VAr-Min maintains records of the last 32 events.
- Operation events can be viewed through the Front Panel in a most recent first order. They will appear as one event per screen similar to this:

```
Opr27 Close
Cause Hi kVAR
Date: 11/18/14
Time: 09:10:23
```

- When events are viewed through the VAr-Min Companion Software, they are stored on the computer's hard drive will be available indefinitely.

5.2. Trending

- The VAr-Min stores 15 minute demands for the following values:
 - kV
 - kW
 - kVAR
 - Temperature
 - Switch Position
- A total of 320 days can be stored
- The VAr-Min Companion Software can calculate any electrical value from the three values stored.
- This data can be displayed in either graphs or in an Excel spreadsheet.

5.3. Delta Voltage

- Each time a switch operation occurs the VAr-Min measures the difference between the voltage before the operation and the voltage after.
- This difference is averaged and maintained for use with the control algorithm.
- This allows the VAr-Min to learn how to anticipate what the voltage will be after an operation so as to make more intelligent control decisions.
- Both the closing and opening delta voltages are stored as separate values.
- These values can be observed and changed in the VAr-Min Companion Software.
- The Learning feature can also be defeated in the VAr-Min Companion Software.

6. Operating Modes

The VAr-Min has three operating modes. These allow a variety of control scenarios to take place.

6.1. Automatic

- Control Operations are done based on the user configured Control Algorithm.
- This mode is indicated on the front panel by a solid amber LED in the Auto/Manual position.
- The VAr-Min will not respond to Close/Trip front panel switch operations.
- The VAr-Min will not close or open the capacitor switches under SCADA or Laptop control.
- This mode can be entered from the Front Panel.
- This mode can be changed to Remote from SCADA or a Laptop

6.2. Remote

- Control Operations are done based on SCADA or Laptop commands.
- This mode is indicated on the front panel by a blinking amber LED in the Auto/Manual position.
- The VAr-Min will not respond to Close/Trip front panel switch operations.
- The VAr-Min will not perform any Control Algorithm Operations.
- This mode can be entered or changed to Automatic from SCADA, Laptop or Special Operation on the Front Panel.
- This mode will be entered if it is in Automatic mode and the Anti-Oscillate function determines that the Control Algorithm is in an oscillating state.
- The mode will be entered if it is in Automatic mode and a Switch Malfunction or Broken Control Cable condition persists for more than 60 seconds.

6.3. Manual

- Control Operations are done based on Close/Trip front panel switch operations.
- This mode is indicated on the front panel by the LED in the Automatic/Manual position being off.
- The VAr-Min will not perform any Control Algorithm Operations.
- The VAr-Min will not close or open the capacitor switches under SCADA or Laptop control.

7. Front Panel

The front panel of the VAr-Min is both simple and elegant. It is very intuitive and user-friendly. It allows complete local control as well as modification of virtually all configuration settings. It also presents Real Time information about electrical conditions and status.

7.1. Switches and LEDs

7.1.1. Auto/Manual Switch

- Place this switch in the up position to put the VAr-Min in Automatic (or Remote) mode.
- Place this switch in the down position to put the VAr-Min in Manual mode.

7.1.2. Auto/Manual LED

- Solid Amber Automatic mode
- Blinking Amber Remote mode
- Off Manual Mode

7.1.3. Close/Trip Switch

- Only used in Manual mode
- Operate this switch up momentarily to initiate a Close operation (20 second delay).
- Operate the switch down momentarily to initiate an Open operation (3 second delay).

7.1.4. Close/Trip LED

- Solid Red Switches are closed
- Solid Green Switches are open
- Red blinking Green Switches are closed but Open operation is pending.
- Green blinking Red Switches are open but Close operation is pending.
- Blinking Orange Switch Malfunction or Broken Control Cable

7.1.5. Special Operations

- Change from Remote Mode to Automatic
 - While pressing the knob (to the right of the display), move the Auto/Manual switch to the down position.
 - Move the Auto/Manual switch back to the up position.
 - After blinking three times the Auto/Manual LED should go solid amber indicating Automatic mode.
- Stop a Close command in Manual Mode
 - While the Close/Trip LED is blinking, operate the Close/Trip switch down momentarily.
 - The LED should stop blinking indicating that the operation is no longer pending.
- Stop a Trip command in Manual Mode
 - While the Close/Trip LED is blinking, operate the Close/Trip switch up momentarily.
 - The LED should stop blinking indicating that the operation is no longer pending.

7.2. Display and Knob

The front panel display and knob are the operator's window to the VAr-Min. The operation of the knob is very intuitive.

In general the knob is rotated to move back and forth between information screens or modify parameters in settings screens.

The knob is pressed to move to the next menu item.

7.3. USB port

This communication port is used with a laptop or other computer running the VAr-Min Companion Software. Use of this software is detailed in a different document entitled "VAr-Min Companion Software Manual."

7.4. Test Jacks

- 7.4.1. Line – Neutral Connect a voltmeter to test the control / measured voltage.
7.4.2. Current – Neutral Connect a voltmeter to test the LPCS signal voltage.

7.5. Fuses

- 7.5.1. 10A Control power – use a 10 amp fuse
7.5.2. 1A Electronics power – use a 1 amp fuse (2 or 3 will work).

7.6. SCADA Communications Access Panel

- 7.6.1. This panel provides access to various SCADA communications devices.
7.6.2. It can be removed using the two thumb screws in the left-hand corners.
7.6.3. Communications Devices
- Ethernet RJ45 Connection: mounts to the Access Panel
 - Fiber Optic ST Connectors: mounts to the bottom board
 - RS-232 Optically isolated DB-9: mounts to bottom board

8. Capacitor Switch Control

There are three types of control: Operator Control (Manual or Remote), Automatic Control and Fast Voltage and Frequency Relaying. The first two of these types of control have certain applicable delays, overrides and inhibits.

8.1. Manual Control

- Manual control operations are the direct result of operator intervention.
- Manual control is only and always done with the Front Panel Auto/Manual switch in the down position.
- Manual close is done by momentarily operating the Close/Trip switch to the up position.
- Manual open is done by momentarily operating the Close/Trip switch to the down position.
- The only inhibit in Manual mode is the 5 minute Discharge Inhibit to close after any open operation. Before closing, this inhibit allows the capacitors to discharge any residual voltage that was left on them when the switches opened.
- Before closing from a manual close initiation there is a 20 second delay. This delay allows the operators to step away from the pole so that they are not directly underneath the rack when the capacitors are energized.

8.2. Automatic Control

- Automatic control operations are the result of a change in conditions that are defined in the Control Algorithm and the Hardware Configuration.
- Operation Delays
 - The 5 minute Discharge Inhibit is active in Automatic Control just as in Manual.
 - The Anti-Oscillate inhibit, if active, will stop frequent operations.
 - The Transient Delay value requires that a switching condition must be valid for the defined time period before initiating the close or open operation.
- The Hardware Configuration can be set in two ways:
 1. Through the Front Panel Hardware Config
 2. Using a laptop running the VAr-Min Companion Software
- The Control Algorithm can be configured in three ways:
 1. Front Panel Control Configuration Wizard
 2. VAr-Min Companion Software Control Configuration Wizard
 3. VAr-Min Companion Software Algorithm Step Programmer
- The Hardware Configuration consists of:
 1. Transformer Phasing
 2. Current Sensor Type
 3. Current Sensor Position
 4. Current Sensor Orientation
 5. Capacitor Bank Size
 6. Primary Voltage
 7. Current Range
 8. Neutral Sensor Type
 9. Neutral Sensor Ratio
 10. Status Sensing
 11. Capacitor Switch Operation Time
 12. Capacitor Switch Open Control
- The Control Configuration Wizard includes:
 1. Primary Control Type
 2. Secondary Control With
 3. Switching Hysteresis
 4. Voltage Override
 5. Voltage Underride
 6. On/Off Times
 7. On/Off Temperatures
 8. Indoor Temperature Time Constant
 9. Transient Delays
 10. Delta Voltage Multiplier
 11. Neutral Sensing Threshold
 12. Anti-Oscillation
 13. Voltage/Frequency Relaying

8.3. Fast Voltage and Frequency Relaying

- Fast Relaying allows the VAr-Min to react quickly to potentially damaging electrical scenarios:
 - Self-exciting condition
 - Feeder breaker closing in to a field full of capacitors
 - Re-strike after taking a shot for a down-line fault
- Fast Relaying works only when the VAr-Min is in Automatic mode.
- Fast Relaying usually involves (but is not limited to) using DC Trip.
- DC Trip requires solenoid operated vacuum switches to be installed.
- DC Trip allows disconnection of the capacitor bank during a power outage.
- Fast Relaying can be programmed to act on:
 - Over-voltage
 - Under-voltage
 - Over-frequency
 - Under-frequency
- Fast Relaying can act in as quickly as 6 cycles

8.4. Control Algorithm

The VAR-Min uses a Control Algorithm to make decisions about operating the capacitor switches. There are two sets of algorithm steps – one for the conditions when the switches are open and the other for conditions when the switches are closed. One set of these steps is evaluated once per second.

The Open Steps are used to form an internal flow chart when the switches are open, while the Closed Steps are used when the switches are closed. Up to ten steps may be programmed for each condition although as few as one is adequate.

Each step is basically a statement which can be either true or false and any given time.

The VAR-Min will take one of three actions depending on the directive for the appropriate case – true or false:

- Leave the capacitor switches as they are. Further steps will not be evaluated during this pass.
- Start or continue the process of toggling the capacitor switches. This involves timeout of the Transient Delay timer. Further steps will not be evaluated during this pass.
- Evaluate subsequent step(s) for additional condition information and directives.

There are five fields in these steps. They are:

- Parameter
 - Voltage with Correction – anticipates the voltage after switches are toggled
 - Voltage
 - Current
 - kW
 - kVAr
 - Frequency
 - Temperature
 - Time
 - Date
 - Day of the Week – Includes a specific Holiday list
- Equate
 - <
 - >
 - =
- Value
 - Open In the Closed Steps: Starts/continues an Open Operation
 In the Open Steps: Leaves switches open
 Terminates evaluation
 - Close In the Open Steps: Starts/continues a Close Operation
 In the Closed Steps: Leaves switches closed
 Terminates evaluation
 - Fast Trip Initiates an Open Operation. Used only in Closed Steps
 Terminates evaluation
 - Next Moves evaluation to the next step
 - Skip Moves evaluation to the step following the next step

These define the logical decision steps in the flow chart. The first three form the equation or statement that will be true or false. The True and False fields determine what to do in either case

Algorithm Example

The following example is a set of switching logic that form an algorithm upon which all actions will be decided. This is a typical algorithm known as switching on VARs with Voltage Override.

Switches Open				Switches Closed			
Step		T	F	Step		T	F
0	VCor < 127.0	N	O	0	volt > 128.0	O	N
1	KVAR > 400	C	O	1	KVAR < - 400	O	C

Assume the following conditions: A 600 kVAR Capacitor bank has switches Open. Voltage is 122.9 and KVAR is 422 (positive kVAR is lagging). Learned delta-V for Close is 1.8 Volts. (At this point only the switching logic under the Switches Open heading will be evaluated.)

Switches Open - Step 0

The capacitor control will begin evaluation at Switches Open - Step 0. Observing Step 0, we find that the present voltage of 122.9 plus the delta-V of 1.8 volts is less than the stated cutoff condition voltage of 127.0 volts shown in Step 0. Therefore the logic evaluates True. The step taken under True is Next indicating that Switches Open - Step 1 will now be evaluated. If the voltage sum were higher than 127.0, then Step 0 would have evaluated False. The action under False would have been to stay Open, and evaluation would terminate. One second later this same step would be evaluated again.

Switches Open - Step 1

The capacitor control has now advanced from Step 0 by the Next action. We see that the present kVAR of 422 is greater than 400, which evaluates True. The action initiated would then be to Close the capacitor bank (after this condition exists for the Close Operation Delay Time). Once the bank is closed, the steps under the Switches Closed heading are evaluated. If the present kVAR were less than 401, the logic would have evaluated False. The action under False would have been to stay Open, and evaluation would terminate. One second later Switches Open - Step 0 would be evaluated again.

Assume the following conditions: The 600 kVAR Capacitor bank is Closed. Voltage is 122.9 and kVAR is -422 (negative kVAR is leading).

Switches Closed - Step 0

The capacitor control now begins evaluation at Switches Closed - Step 0. Observing Step 0, we find the present voltage of 122.9 is less than 128.0, which evaluates False. The action taken under Step 0 for False is to go to the Next step (Step 1 under Switches Closed heading). If the voltage had been greater than 128.0 volts, the logic for Step 0 would have evaluated True. In which case, the action initiated under True would be to Open the capacitor bank if this condition persisted for the Open Operation Delay Time.

Switches Closed - Step 1

The capacitor control unit having taken a Next action in Step 0 now begins evaluation of Step 1. Notice logic states the kVAR must be less than cutoff point of -400 to be evaluated True. Since the present kVAR is -422, which is less than -400. The step is evaluated True, and the step taken is Open. If the kVAR had not been less than -400, Step 1 would have evaluated False. The action taken under False would have been to stay Closed, and evaluation would terminate. One second later Switches Closed - Step 0 would be evaluated again.

Algorithm Steps in the Front Panel

The currently operational Control Algorithm can be viewed (not changed) through the front panel display. They will appear something like this:

	Open	Steps	TF
0	volt	<118.5	CN
1	vCor	>130.0	ON
2	kVAr	> 400	CO

	Closed	Steps	TF
0	volt	>130.0	ON
1	vCor	<118.5	CN
2	kVAr	< -400	OC

8.5. Hardware Configuration Settings

In most cases this group settings will describe the parameters of the line, the load and the capacitor bank rack that are necessary for the VAR-Min to do its job.

A questionnaire can be found in the Config Menu in the front panel display that facilitates entering these values.

8.5.1. Transformer Phasing

The transformer primary on the rack may be connected Phase-Neutral (more common) or Phase-Phase.

When it is Phase-Neutral the VAR-Min will assume that the LPCS is on the same phase as the transformer and will use an internal phase angle offset of 0°.

When it is Phase-Phase the VAR-Min will assume that the LPCS is on the phase that is not connected to the transformer primary and will use an internal angle offset of 90°.

The internal angle offset can be changed to any value through the VAR-Min Companion Software.

8.5.2. Current Sensor Type

Each LPCS type has different characteristics.

They all send a voltage signal that indicates approximately 60 amps / volt.

But the current phase shift is different for each:

- Lindsey Multi-Core 0°
- Fisher-Pierce x7A 90°
- Fisher-Pierce x1A 104°

Based on the LPCS selection, the internal angle offset will be adjusted by the indicated amount.

8.5.3. Current Sensor Position

The LPCS can only measure current that is flowing from the source to loads that are downline from it.

When the LPCS is on the Source side of the bank the VAR-Min can “see” the capacitor bank as well as the downline load.

When the LPCS is on the Load side of the bank the VAR-Min cannot see the capacitor bank. It can only see the downline load.

It is preferable to have the LPCS on the Source side of the bank since the VAR-Min can then measure the effects of energizing the bank.

This setting allows for both conditions.

When the LCPS is on the Source side, the Algorithm Wizard will use a kVAR hysteresis of 4/3 the bank size since the measured kVAR will change after an operation by the approximate size of the capacitor bank.

When the LCPS is on the Load side, the Algorithm Wizard will use a kVAR hysteresis of 1/3 the bank size since the measured kVAR will not change appreciably after an operation.

8.5.4. Current Sensor Orientation

Changing the orientation of the LPCS changes the phase angle relative to the voltage by 180°. Mathematically this reverses the sign of kW and kVAR.

The VAR-Min can compensate for incorrect LPCS orientation. It has three possible orientation settings:

- Auto-Correct LPCS orientation does not matter
- Standard LPCS is correctly installed
- Reversed LPCS is installed with reverse orientation

8.5.5. Capacitor Bank Size

This is the three phase size of the bank in units of kVAr.

The bank size is important when using Switching on kVAr as part of the control algorithm.

The Algorithm Wizard will use a kVAr hysteresis of 4/3 the capacitor bank size when the LPCS is on the source side of the bank and 1/3 the bank size when the LPCS is on the load side.

See the section on Current Sensor Position above.

8.5.6. Primary Voltage

This is the nominal primary Phase-Neutral voltage in volts.

It is necessary for accurate kVAr and kW calculations.

8.5.7. Current Range

This parameter allows adjustment of the front end gain in the current amplifier circuit.

In the majority of cases the default setting (0 – 180 amps) is adequate. But occasionally a higher range is required.

This can be determined by using a voltmeter to read the signal from the LPCS.

It is best to keep the range as low as possible while insuring that the measured current will always be within the indicated limits.

The higher the range the lower the resolution is on the current reading.

8.5.8. Neutral Sensor Type

Capacitor Neutral Sensing is used to detect one or more blown capacitor fuses.

This sensing can only be used when the capacitors are in a wye configuration because a delta has no neutral point.

Two types of sensors are used:

- CT – Used with a grounded wye
- PT – Used with an ungrounded wye

8.5.9. Neutral Sensor Ratio

This allows setting the primary to secondary current or voltage ratio of the sensor.

8.5.10. Status Sensing

The VAr-Min is able to sense status of the three capacitor switches through the Close and Trip wires in the control cable.

Most capacitor switches have internal micro-switches that disconnect the close pin when the switch is closed and that disconnect the trip pin when the switch is open.

The VAr-Min takes advantage of this by measuring the resistance from the close and trip switch connector pins to the common pins of each switch.

This allows the detection of four possible conditions:

- Closed All switches closed
- Open All switches open
- Switch Malfunction Switches not in same position
- Control Cable Broken Switch position not detected

Some switches do not have this type of micro-switch setup. In this case auxiliary switches can be used to provide position feedback to the VAr-Min. Usually in these cases only the first two conditions are detectable.

In order to cover all possible scenarios the VAr-Min has four status sensing alternatives:

- No Sensing Uses the last commanded position as the current status
- Trip Wire Uses the trip wire for status sensing
- Close Wire Uses the close wire for status sensing
- Both Wires Uses both wires for status and malfunction sensing

In some rare cases no position information is available so the last-command-issued (No Sensing) scenario must be used.

8.5.11. Capacitor Switch Operation Time

This allows modification of the amount of time then the VAr-Min will apply a close or trip command to the switches.

8.5.12. Capacitor Switch Open Control

This selects whether the VAr-Min will use normal AC tripping or the faster DC tripping. DC tripping can only be used with solenoid operated vacuum switches.

See the section on Fast Relaying above.

8.6. Control Configuration Wizard

This Wizard is essentially a questionnaire which when completed will produce settings and a control algorithm that will cause the VAr-Min to behave in the desired way. It can be found either in the Config Menu of the front panel display or in the VAr-Min Companion Software.

Parameters 1-7 and 13 below will directly affect the control algorithm. The rest will not.

Here are the basic components of the questionnaire.

8.6.1. Primary Control Type

This is main parameter that the VAr-Min will use to control the capacitor bank switching.

The possible entries are:

- kVAr
- Time
- Temperature
- Time & Temp
- Voltage

8.6.2. Secondary Control (Override)

This is an override parameter which the VAr-Min will evaluate first before acting on the Primary Control parameter. Its function is to allow normal control activity only when favorable conditions exist.

This control parameter will appear in the algorithm before the Primary Control.

An example would be kVAr with Voltage Override. This would mean that the VAr-Min would control on kVAr but only within a safe voltage range. Control when outside this voltage range would be governed by the Voltage Override values (see below).

The possible entries are:

- None
- Day of the Week
- Voltage
- DOW & Voltage

8.6.3. Switching Hysteresis

This parameter is only active and will only appear when using kVAr as the Primary Control. It allows varying the Close and Open kVAr settings.

8.6.4. Voltage Override

This parameter is only active and will only appear when using Voltage as the Primary Control or Voltage (or DOW & Voltage) as the Secondary Control.

The value set here will be the highest voltage that the VAr-Min will allow the capacitor bank to be energized with.

8.6.5. Voltage Underride

This parameter is only active and will only appear when using Voltage as the Primary Control or Voltage (or DOW & Voltage) as the Secondary Control.

The value set here will be the lowest voltage that the VAr-Min will allow the capacitor bank to be de-energized with.

8.6.6. On/Off Times

These parameters are only active and will only appear when using Time or Time & Temp as the Primary Control. They specify the times of day when the bank will be switched on and then when it will be switched off.

8.6.7. On/Off Temperatures

These parameters are only active and will only appear when using Temperature or Time & Temp as the Primary Control. They specify the estimated indoor temperatures at which the bank will be switched on and at which it will be switched off.

8.6.8. Indoor Temperature Time Constant

This parameter sets the time constant (in minutes) for estimating the average indoor temperature in the local area. Naturally this will vary by general climate and density of air conditioning equipment.

When this value is set to zero, the Indoor Temp is always the same as the measured Ambient Temp.

The temperature sensor is an optional feature of the VAr-Min.

8.6.9. Transient Delay

This delay sets the amount of time that the control algorithm must continually evaluate to switching before actually initiating the close or trip.

This eliminates transient conditions erroneously causing an operation.

It also allows staging when there are more than one bank on a feeder. It is prudent to have downline banks operate before banks closer to the source. This is because the upline VAr-Mins can see the downline banks but the converse does not hold.

8.6.10. Delta Voltage Multiplier

When this value is non-zero the Transient delay is modified by the Switching Delta Voltage times this multiplier.

The modification is to subtract this product from the Transient Delay.

On multiple bank feeders this has the effect of causing the banks where the voltage changes the most at switching to operate quickest.

This feature is sometimes used in voltage control applications.

8.6.11. Neutral Sensing Threshold

This parameter is only active and will only appear when a Neutral Sensor has been selected in the Hardware Configuration.

It sets the current or voltage threshold for detection of a blown capacitor fuse.

8.6.12. Anti-Oscillation

This entry will enable or disable the Anti-Oscillation feature.

8.6.13. Voltage/Frequency Relaying

Setting this entry to "Yes" will add Voltage and Frequency Fast Tripping steps to the control algorithm. These steps will appear before the Secondary and Primary Control steps.

By default the steps added are –

Fast Trip if:

1. Frequency goes above 61.00 Hz
2. Frequency goes below 59.00 Hz
3. Voltage goes above 140.0 VAC
4. Voltage goes below 95.0 VAC

They can be changed using the VAr-Min Companion Software.

8.7. SCADA Configuration Settings

8.7.1. Modbus Address

- This is the address for Modbus protocol
- The range is 1 to 253

8.7.2. Modbus Baud Rate

- This is the baud rate for Modbus protocol
- Selectable baud rates are
 - 2400
 - 4800
 - 9600
 - 19.2K
 - 38.4K
 - 57.6K
 - 115.2K

8.7.3. DNP Address

- This is the DNP 3.0 protocol address
- The range is 1 to 65532

8.7.4. DNP Baud Rate

- This is the baud rate for DNP 3.0 protocol
- Baud rate selection is the same as for Modbus

8.7.5. DNP Clock Source

- The DNP 3.0 protocol requires a clock source for keeping track of time stamped events.
- The VAR-Min allows two options for this:
 - Internal RTC
 - Uses the VAR-Min's Real Time Clock
 - When the DNP master issues a command to set the clock, the VAR-Min's RTC will be set.
 - SCADA Master
 - This option will keep the DNP Clock and the VAR-Min clock isolated from each other
 - The DNP server will get its time only from the SCADA master.
 - With any firmware reset, the DNP server will raise the Time Sync IIN bit.

8.8. Date & Time Set

- Accurate time is important for event and trend data storage as well as for some of the control algorithm parameters to operate properly.
- Date and Time can be set from the front panel or using the VAR-Min Companion Software. It can also be set from either Modbus or DNP3.0 protocols.
- When setting date & time the front panel:
 - Access the Date and Time screen from the Config Menu
 - Hold the knob in a pressed in position until a flashing cursor appears on the screen.
 - Rotate the knob to modify each time parameter.
 - Press the knob to move the cursor to the next parameter.
 - DOW (Day of Week) is 1 for Monday through 7 for Sunday

9. Front Panel Display Description

The Front Panel Display is the operator's easiest way for setting the VAr-Min up in the field. It is very intuitive and user-friendly. Getting through the various screens requires only the use of the knob to the right of the display. The knob can both be rotated and pressed.

9.1. Splash Screen

- This screen comes up when the unit is powered or a reset occurs.
- It shows the firmware version number.
- After 3 seconds the screen will change to display the Real Time Information.
- This screen can be re-entered by holding down the knob from any of the Electrical screens in the Real Time Information.

9.2. Real Time Information

This information is derived from immediately measured data or status.

- Rotating the knob will move between screens.
- Pressing the knob will bring up the Config Menu (See below).

9.2.1. General

This screen will show

- Unit ID
 - The Unit ID can be set using the VAr-Min Companion Software
- Operations Count
 - Operations count is incremented each time status changes from closed to open.
 - This count can be cleared in the VAr-Min Companion Software
- Date/Time
 - Date and Time can be set from the front panel or using the VAr-Min Companion Software. It can also be set from either Modbus or DNP3.0 protocol interfaces.

9.2.2. Electrical – Basic

This screen displays information measured from the transformer and LPCS:

- Voltage (nominal 120 or 240 VAC)
- Current
- Power Factor in percent

9.2.3. Electrical – Primary

This screen displays information calculated from transformer and LPCS measurements:

- Primary Voltage (Phase-Neutral) in kilovolts
- Line Frequency
- Phase Angle in degrees

9.2.4. Calculated Power Flow

Displayed here are estimated three phase power values calculated from single phase transformer and LPCS measurements:

- kW
- kVAr
- kVA

9.2.5. Source/Load Comparison

This screen displays a side by side comparison of pertinent source and load parameters. Of course when the capacitors are de-energized both sides will be the same.

- kVAr (three phase estimate)
- Current
- Power Factor in percent

9.2.6. Electrical – Capacitor Bank

This shows capacitor bank electrical values based on the transformer reading, the configured capacitor bank size and the neutral sensor configuration:

- kVAr – This varies by the square of the voltage.
- Current – Source will be less than Load if the bank is sized properly.
- Neutral – Displays actual capacitor neutral current or voltage difference.

9.2.7. Temperatures

Temperatures are shown if an optional Temp Probe is installed. Otherwise values will be zero and the bottom line will show: “No Temp Sensor”.

- Ambient Temperature is the instantaneous measured temperature
- Indoor Temperature is the estimated indoor temp based on the ambient history and a time constant that can be modified in the hardware settings.

9.2.8. Control Status

This screen displays several items of information:

- Cap bank status
 - Open
 - Closed
- Operating Mode – See the section on Operating Modes
 - Manual
 - Automatic
 - Remote
- Operation Delays – See Operation Delays under Automatic Control
 - Discharge Inhibit
 - Transient Delay
 - Anti-Oscillate Inhibit
 - Stable
- Delay Status
 - Pending operation with time till initiation
 - Nothing Pending

9.3. Config Menu

This screen gives access to all front panel configurable settings and operation history. It is entered by pressing the knob from any of the Real Time Information screens.

- Back Returns to the *Real Time Information* screens
- Hardware Refer to the *Hardware Configuration Settings* section
- Wizard Refer to the *Control Configuration Wizard* section
- Date/Time Refer to the *Date & Time Set* section
- SCADA Refer to the *SCADA Configuration* section
- Algorithm Refer to the *Control Algorithm* section
- Operations Refer to the *Operation History* section
- Real Time Returns to the *Real Time Information* screens

9.4. Display Screen Flow Diagrams

The following is a detailed description of the VAr-Min Front Panel Display Screens.

Current Conditions Screens

S1

Press knob to go to
Configuration Menu: Page S2

UAr-Min
Version 8.08
Valquest Systems

Unit ID 2950
Operations 382
Date 06/21/14
Time 09:47:27

Splash Screen

Electrical
Voltage 125.8
Current 87.1
Power Factor 96

Rotate knob to move between these

Electrical
kV P-N 7.55
Frequency 60.02
Phase Angle 16°

Power Flow
kW 1882
kUAr 549
kVA 1960

Line	Src	Load
kUAr	549	1209
Amps	87	99
PF%	96	84

Capacitor Bank
kUAr 660
Current 29
Neutral 1

Temperature
Ambient 77°F
Indoor 73°F

Status: Closed
Manual Mode
Dischrge Inhibit
Open in 04:17

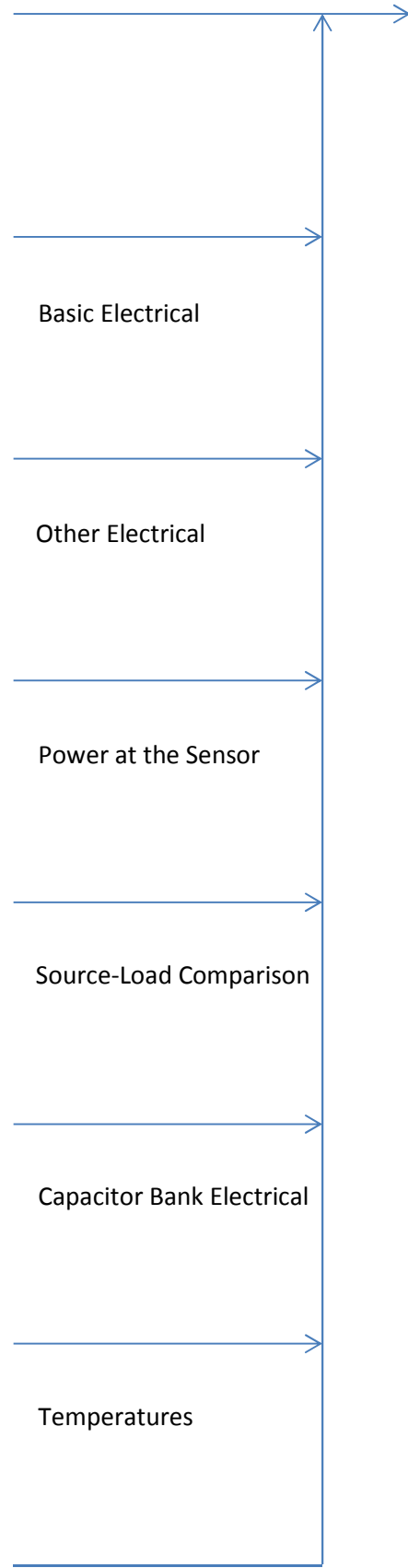

Status Information

Press knob to do selected configuration

Rotate knob to move cursor up/down

```
**** Config ****
>> Hardware
    Wizard
    SCADA
```

To Hardware Config: Page S3

Configures rack components

```
**** Config ****
>> Hardware
    Wizard
    SCADA
```

To Wizard Config: Page S5

Configures control parameters

```
*** Config ****
>> Hardware
    Wizard
    SCADA
```

To SCADA Config: Page S12

Configures Address and Baud

```
**** Config ****
>> Date/Time
    Algorithm
    Operations
```

To Date/Time Set: Page S13

```
**** Config ****
>> Date/Time
    Algorithm
    Operations
```

To Algorithm View: Page P14

Shows Control Algorithm steps

```
**** Config ****
>> Date/Time
    Algorithm
    Operations
```

To Operations View: Page 15

Shows Operations / Events

```
**** Config ****
>> Algorithm
    Operations
    RealTime
```

Back to Current Conditions

Page S1

Press knob to move to the next screen

Rotate knob to modify values

```
**** Config ****
» Hardware
  Wizard
  SCADA
```

Transformer Primary

When Phase-Neutral:
Current Sensor and Transformer
Should be on the same Phase

When Phase-Phase:
Current Sensor should be on
phase opposite Transformer

```
Xformer Primary
» Phase-Neutral
  Phase-Phase
```

Line Post Current Sensor Type

```
LP Sensor Type
» Lindsey M-Core
  FshrPierce x7A
  FshrPierce x1A
```

Sensor Position

When possible, the Current
Sensor should be on the
Source side of the switches

```
Sensor Position
Relative to Bank
» Source Side
  Load Side
```

Current Phase adjust (0 or 180 deg)

Use Auto Correct in most cases

```
Current Phasing
» Auto-Correct
  Standard
  Reversed
```

Bank Size: 50 kVAr increments

```
Capacitor Bank
  600 kVAr
```

Primary Voltage: 20 volt increments

```
Primary Voltage
  7200 Volts
```

Current Range: from max 180 to 1530

```
Current Range
» 0 - 180 Amps
  0 - 270 Amps
  0 - 360 Amps
```

Cap Bank Neutral Sensing
For blown fuse detection
Use CT for Grounded Y
Use PT for Ungrounded Y

Cap Fuse Sensing
No Sensing
» **CT (Gnd Y)**
PT (UnGnd Y)

Neutral Sensing CT Ratio
Seen only when Cap Fuse
Sensing (above) was set to CT

Neutral Sensing
CT Ratio 20:5

Neutral Sensing PT Secondary Voltage
Seen only when Cap Fuse
Sensing (above) was set to PT

Neutral Sensing
PT Voltage 120

Switch Status Sensing
When possible, use Both

Status Sensing
Trip Wire
Close Wire
» **Both Wires**

Capacitor Switch operation time)
Use 2 sec for solenoid switch
Use 7 sec for most motor
operated switches

Switch Operation
Time: 2 sec
Solenoid Switch

Switch Opening Control Method
Use DC trip with solenoid
switches only. Never
with motor switches

Switch Operation
Open Control
AC Trip
» **DC Trip**



Back to Configuration Menu

Press knob to move to the next screen

Rotate knob to modify values

```
**** Config ****
» Wizard
  SCADA
  Date/Time
```

Rotate knob to select Primary Control

```
Primary Control
» kVAr
  Time
  Temperature
```

To Wizard – kVAr: Page S6

Line Post Current Sensor Type

```
Primary Control
  kVAr
» Time
  Temperature
```

To Wizard – Time of Day: Page S7

Sensor Position

When possible, the Current Sensor should be on the Source side of the switches

```
Primary Control
  kVAr
  Time
» Temperature
```

To Wizard – Temperature: Page S8

Current Phase adjust (0 or 180 deg)
Use Auto Correct in most cases

```
Primary Control
  Time
  Temperature
» Time & Temp
```

To Wizard – Time/Temp: Page S9

Bank Size: 50 kVAr increments

```
Primary Control
  Temperature
  Time & Temp
» Voltage
```

To Wizard – Voltage: Page S10

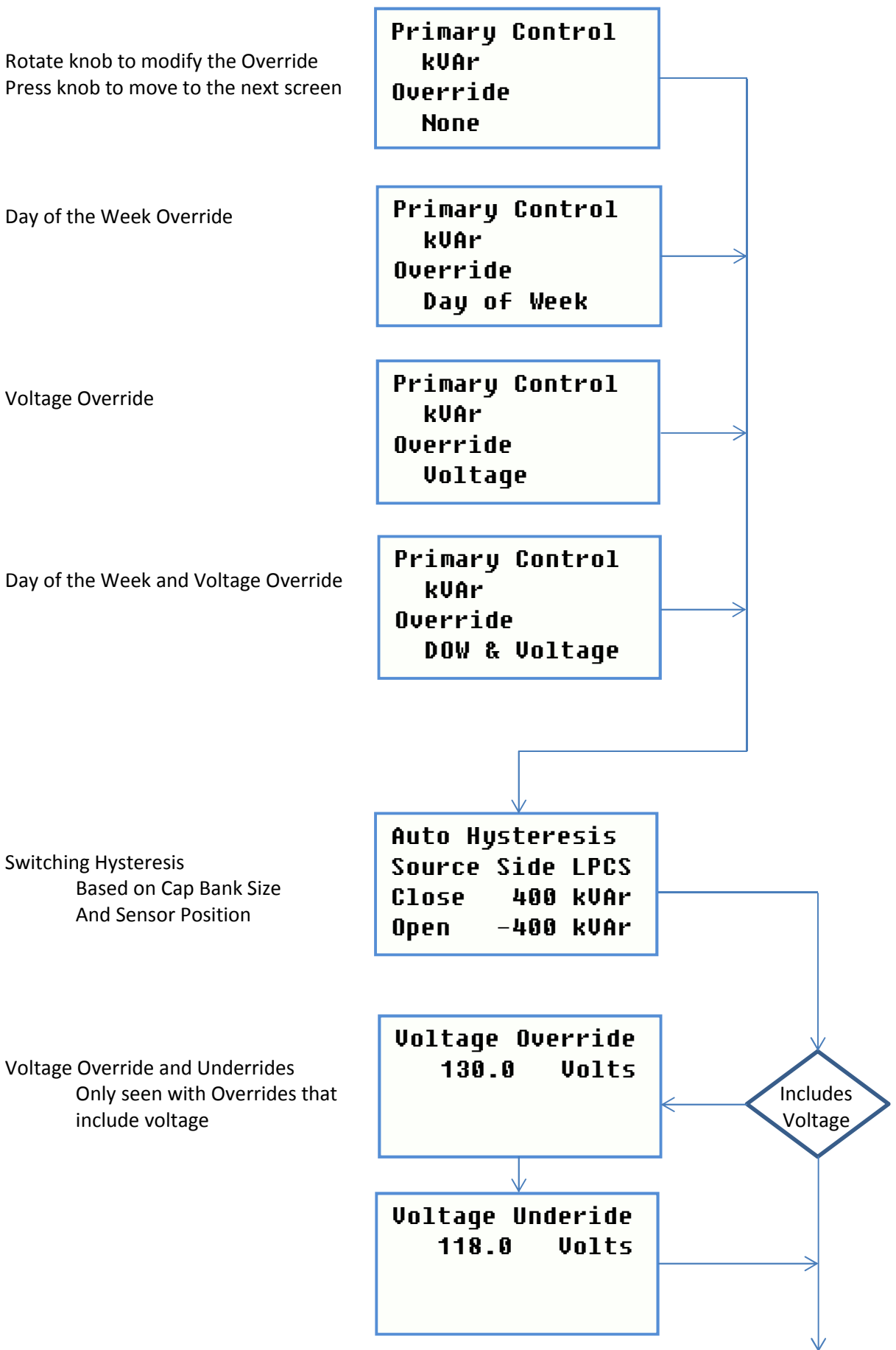

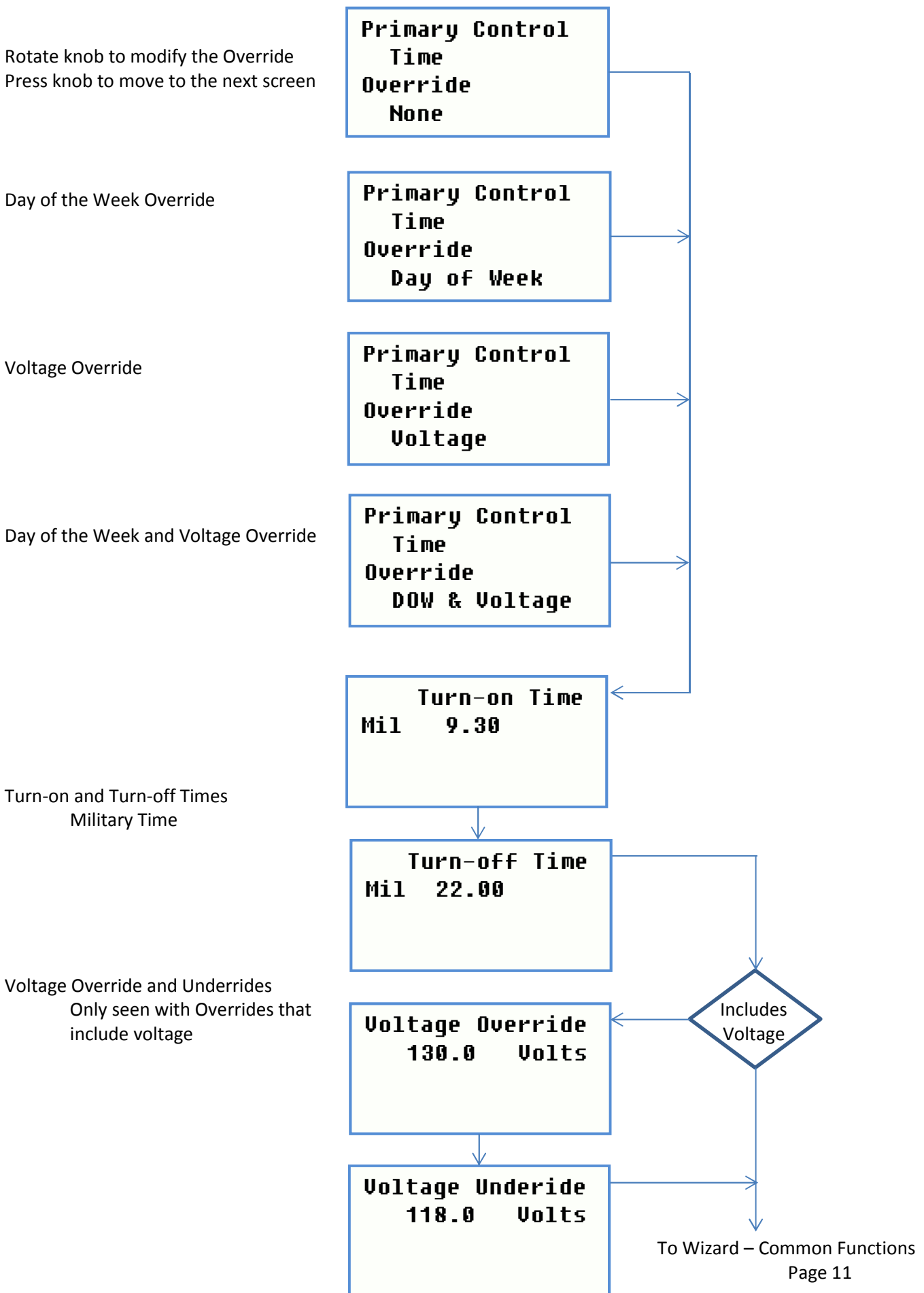

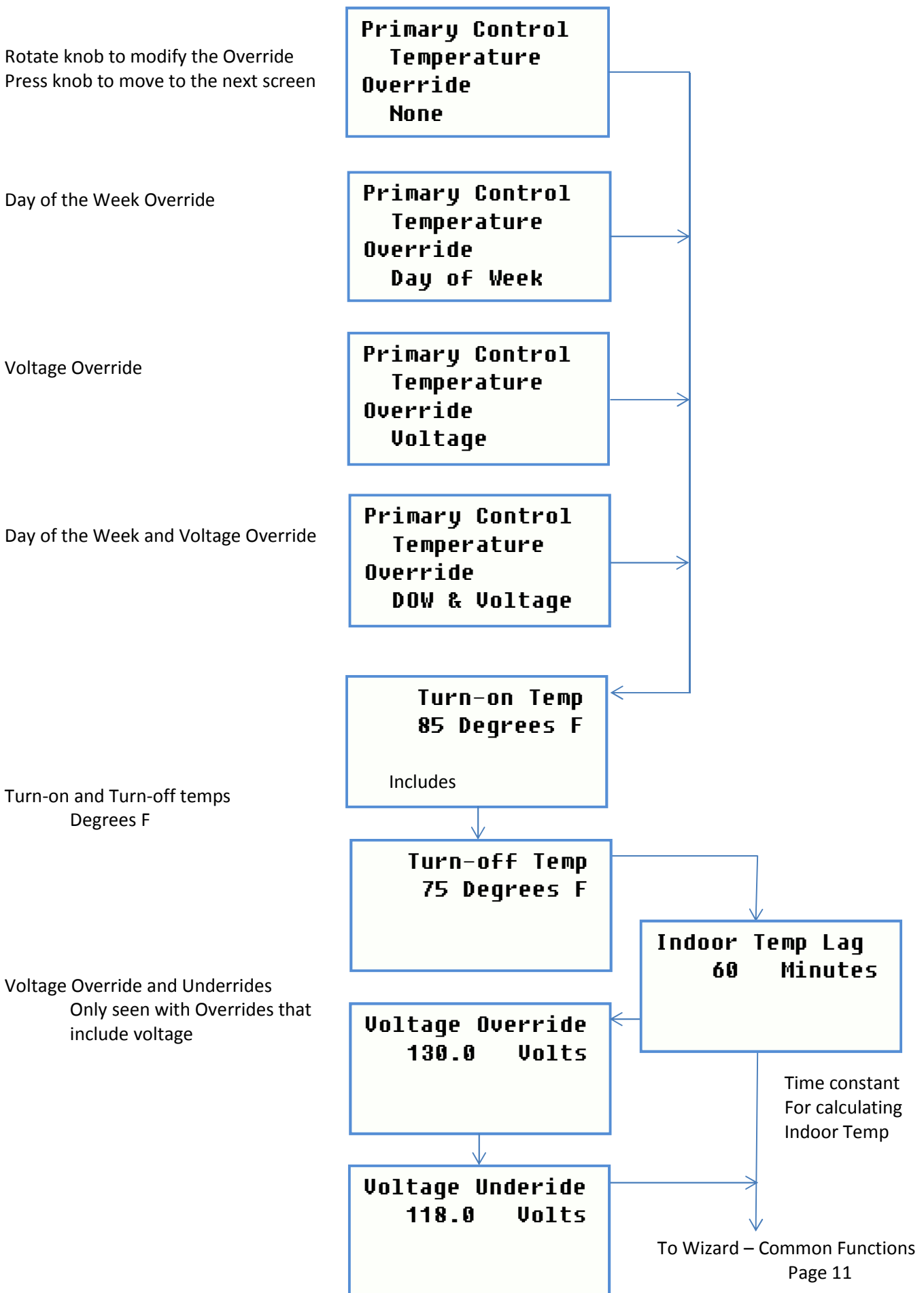

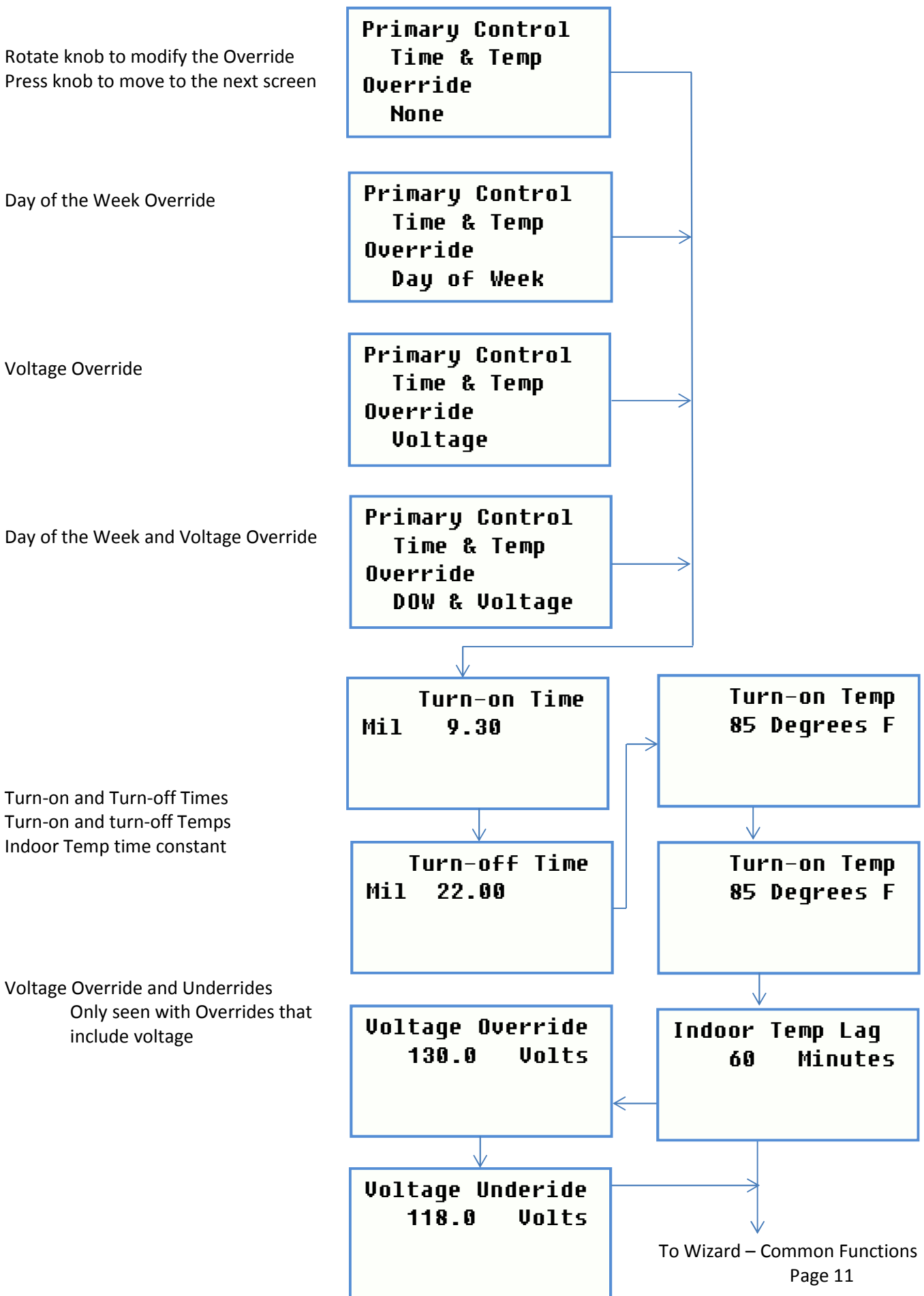

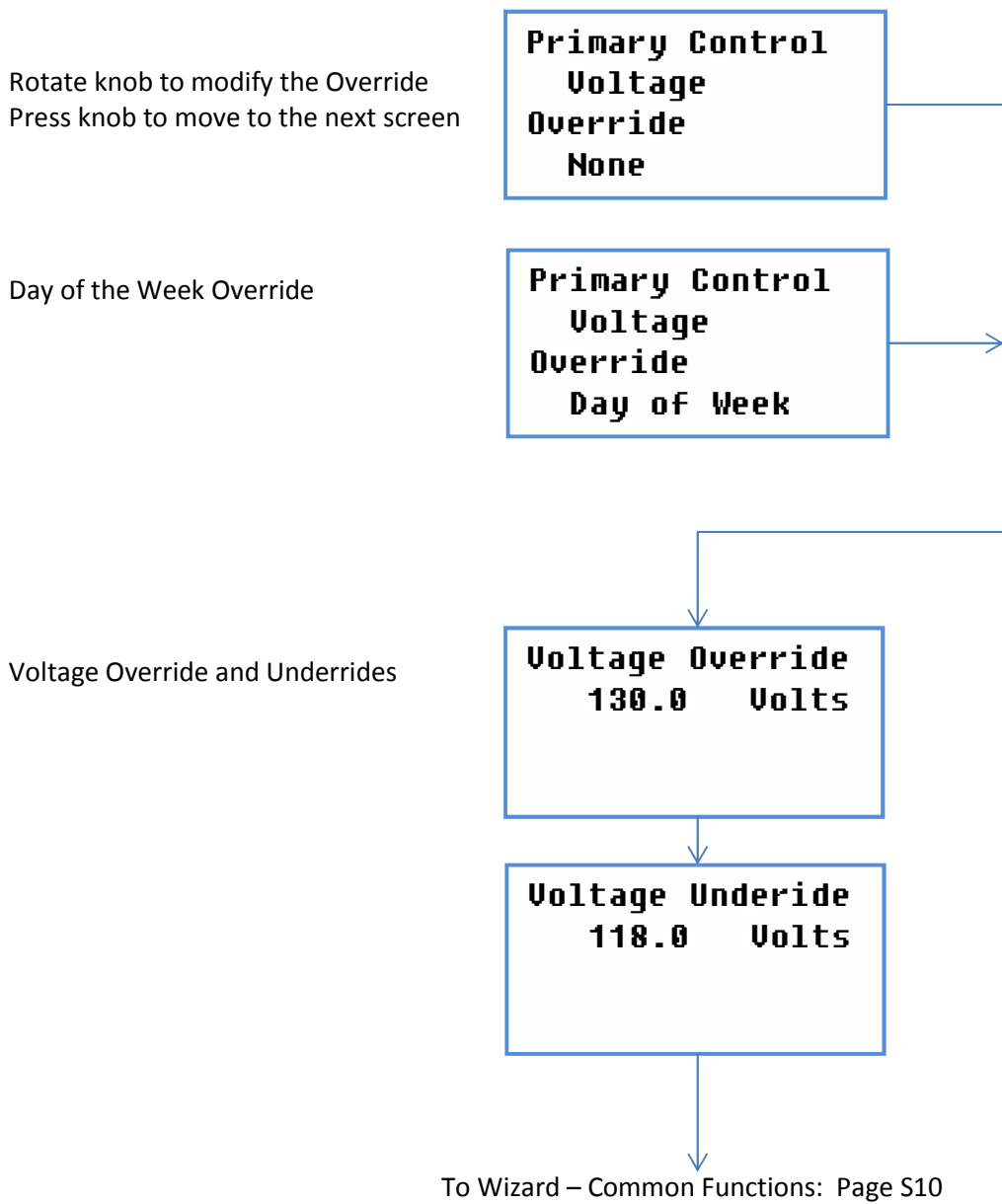

Press knob to move to the next screen
Rotate knob to modify values

Delay for Operation
Time the condition must remain
to initiate a close or open operation

Transient Delay
18 Seconds

Transient Delay Modifier
This number times the delta voltage
Is subtracted from the Transient
Delay at operation time

dV Multiplier
15 Sec/Volt

Threshold for blown fuse indication
Seen only if Neutral Sensing CT was
selected in Hardware Menu items

Neutral Thrshold
30 Amps

Threshold for blown fuse indication
Seen only if Neutral Sensing PT was
selected in Hardware Menu items

Neutral Thrshold
20 Volts

Anti-Oscillation Shutoff
See section on Anti-Oscillate feature

Anti Oscillation
Inhibit
Active
» Inactive

Voltage and Frequency Relaying enable

Use Volts & Freq
for DC Trip
No
» Yes



Back to Configuration Menu

Press knob to move to the next screen
Rotate knob to modify values

Modbus Address (1 – 254)

Modbus Address
52

Modbus Baud Rate (1200 – 115200)

Modbus Baud Rate
4800
>> 9600
19200

DNP 3.0 Address (1 – 65533)

DNP Address
2001

DNP 3.0 Baud Rate (1200 – 115200)

DNP Baud Rate
2400
4800
>> 9600

DNP 3.0 Clock Source
Internal RTC uses VAr-Min clock

DNP Clock Source
>> Internal RTC
SCADA Master



Back to Configuration Menu

Press & Hold knob to set date and time

Date	Mo	Da	Yr
	11	18	14
Time	Hr	Mn	Wk
	08	56	3

Press knob to move the cursor
Rotate knob to modify values

Date	Mo	Da	Yr
	<u>11</u>	18	14
Time	Hr	Mn	Wk
	08	56	3

Date	Mo	Da	Yr
	11	18	14
Time	Hr	Mn	Wk
	09	<u>56</u>	3



Back to Configuration Menu

Press knob to move to the next screen

Rotate knob to roll steps

Open Steps

If more than 3 steps – rotate knob

	Open	Steps	TF
0	Volt	<118.0	CN
1	UCor	>130.0	ON
2	kVAr	> 400	CO

Closed Steps

If more than 3 steps – rotate knob

	Closed	Steps	TF
0	Volt	>130.0	ON
1	UCor	<118.0	CN
2	kVAr	< -400	OC



Back to Configuration Menu

Rotate knob to see different events
Press knob to return to Config Menu

Events start with most recent

Opr00 Open
Cause External
Date: 11/20/14
Time: 09:15:51

Opr01 Close
Cause Hi kVAr
Date: 11/18/14
Time: 09:10:23

Opr02 Open
Cause Manual
Date: 11/17/14
Time: 08:33:33



Back to Configuration Menu

10. Communications

The VAr-Min has three completely independent communications ports.

- Port 1 – USB on the front panel for use with a laptop or other device.

Ports 2 and 3 are reached through the Communications Access Panel.

Various communications modules are optional devices:

- Ethernet module
- Fiber Optics with ST connections
- Fiber Optics with V-Pin connections
- Fiber Optics with plastic 1000 micron duplex
- Serial with opto-coupled DB9
- Serial with opto-coupled Phoenix connector

Port 2 – Modbus Protocol

- Modbus – TCP (if Ethernet module is installed)
- Modbus – RTU over Ethernet
- Modbus – RTU over serial
- Modbus – RTU over fiber

Port 3 – DNP 3.0

- DNP over Ethernet
- DNP over serial
- DNP over fiber

Modbus and DNP 3.0 can be used simultaneously.

11. Appendix

The Appendix Includes:

- 11.1. Meter Base Configurations
- 11.2. Figure 1 – VAr-Min Pole Configuration
- 11.3. Figure 2 – VAr-Min Pole Grounding
- 11.4. Modbus Register Description
- 11.5. DNP 3.0 Data Directory

Meter Base Configurations

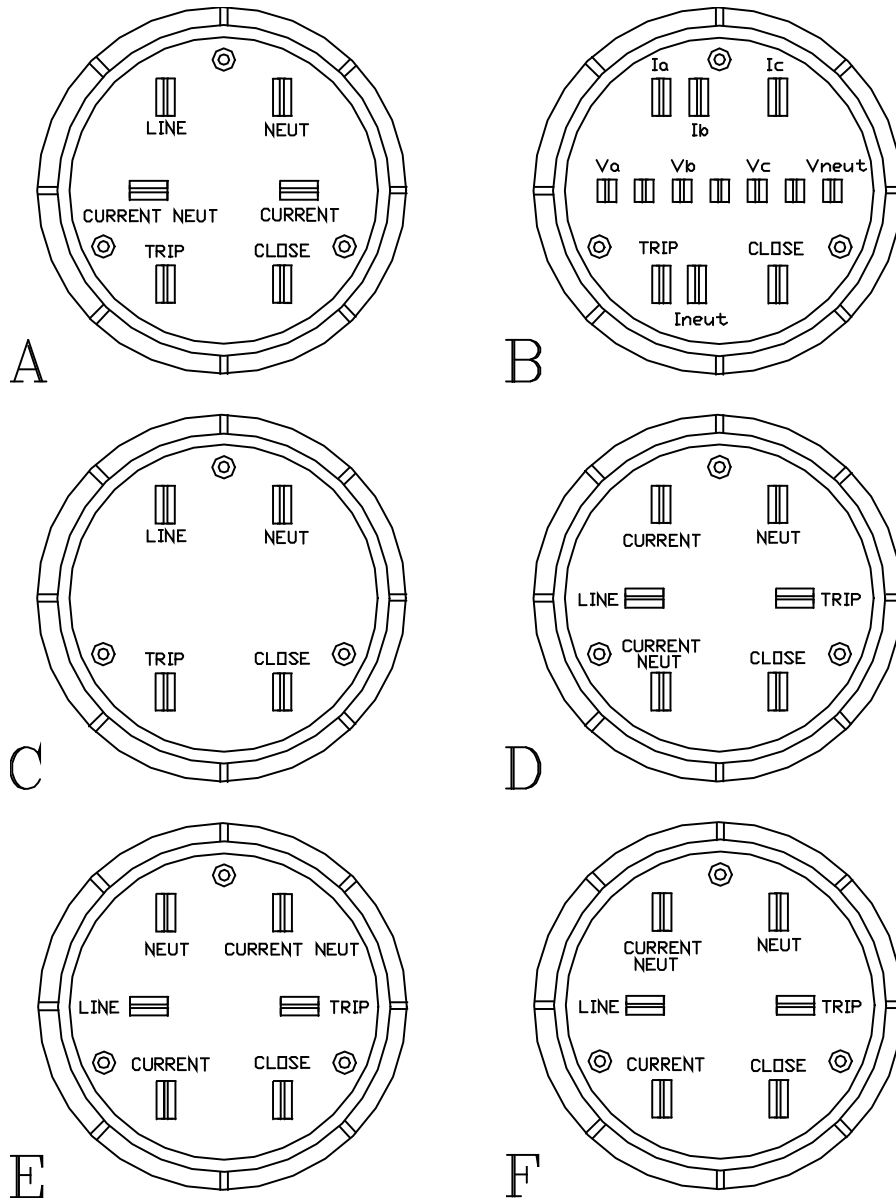

Diagrams are shown looking into the wired meter base (not looking at back of VAr-Min).

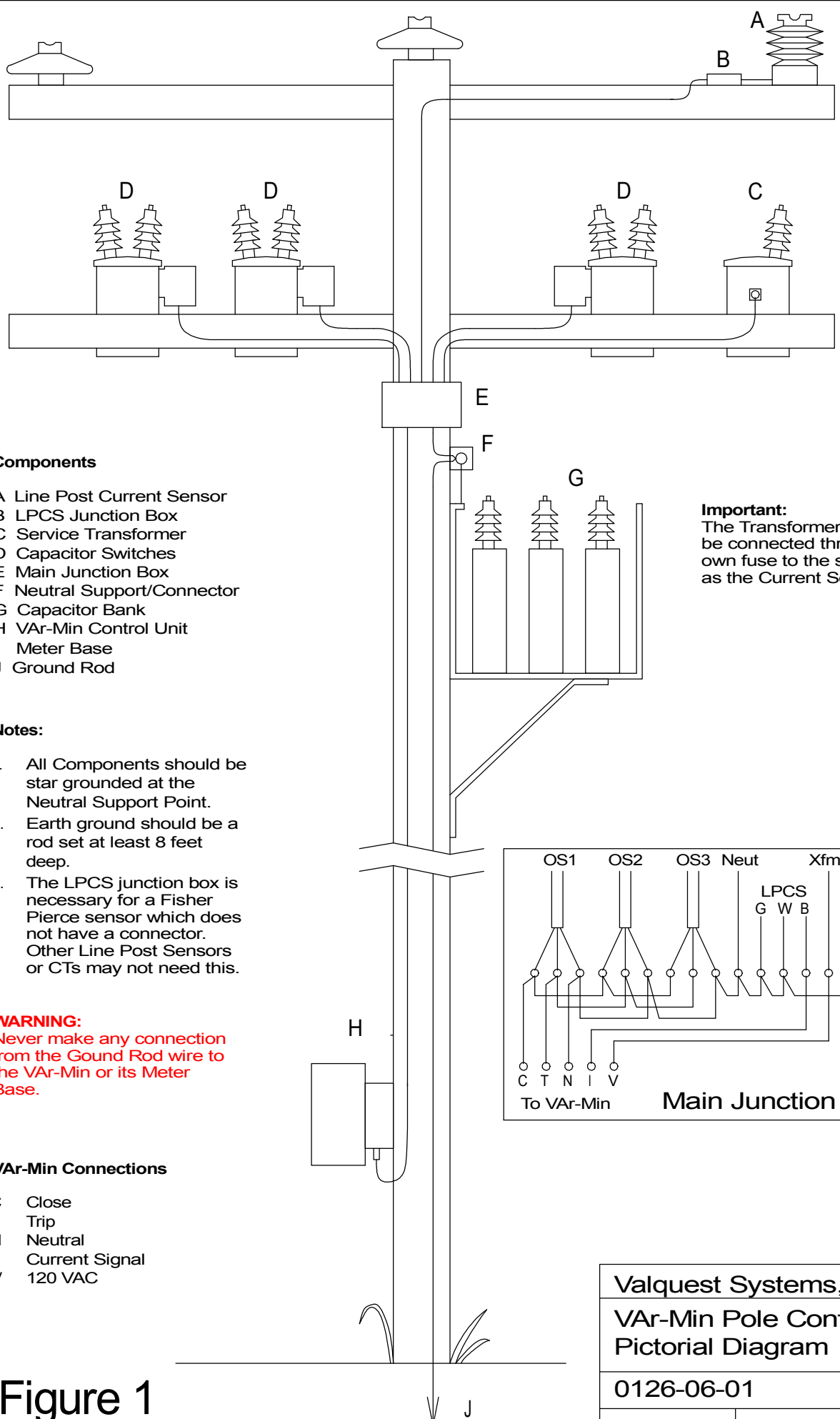

Components

- A Line Post Current Sensor
- B LPCS Junction Box
- C Service Transformer
- D Capacitor Switches
- E Main Junction Box
- F Neutral Support/Connector
- G Capacitor Bank
- H VAR-Min Control Unit
- I Meter Base
- J Ground Rod

Important:

The Transformer (C) should be connected through its own fuse to the same phase as the Current Sensor (A).

Notes:

1. All Components should be star grounded at the Neutral Support Point.
2. Earth ground should be a rod set at least 8 feet deep.
3. The LPCS junction box is necessary for a Fisher Pierce sensor which does not have a connector. Other Line Post Sensors or CTs may not need this.

WARNING:

Never make any connection from the Ground Rod wire to the VAR-Min or its Meter Base.

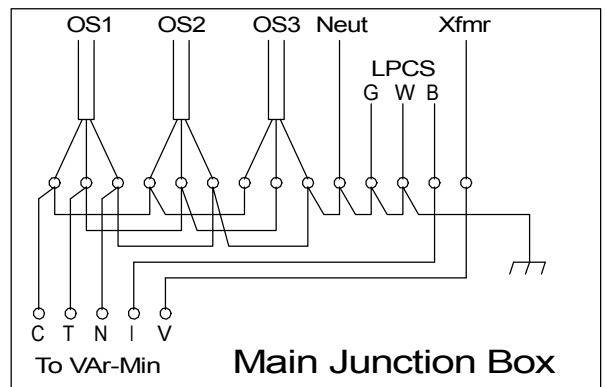

VAR-Min Connections

- C Close
- T Trip
- N Neutral
- I Current Signal
- V 120 VAC

Figure 1

Valquest Systems, Inc.

VAR-Min Pole Configuration Pictorial Diagram

0126-06-01

12-31-91

T. Landes

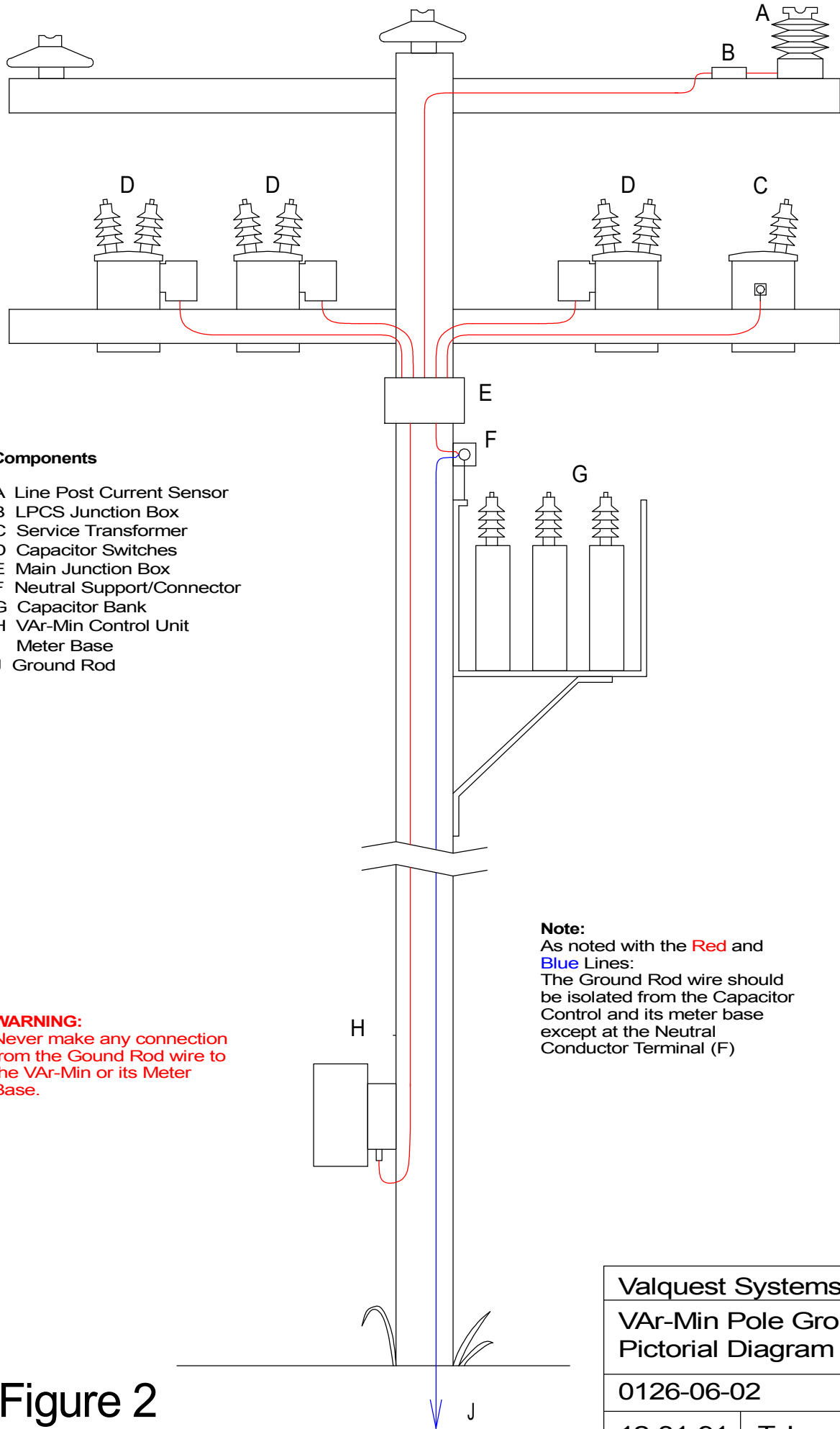

Components

- A Line Post Current Sensor
- B LPCS Junction Box
- C Service Transformer
- D Capacitor Switches
- E Main Junction Box
- F Neutral Support/Connector
- G Capacitor Bank
- H VAR-Min Control Unit
- I Meter Base
- J Ground Rod

WARNING:
 Never make any connection from the Ground Rod red wire to the VAR-Min or its Meter Base.

Note:
 As noted with the Red and Blue Lines:
 The Ground Rod wire should be isolated from the Capacitor Control and its meter base except at the Neutral Conductor Terminal (F)

Figure 2

Valquest Systems, Inc.		
VAR-Min Pole Grounding Pictorial Diagram		
0126-06-02		
12-31-91	T. Landes	1/1

Valquest Systems, Inc
VAr-Min SR2 Modbus (with Float Parameters)

Supported Modbus Function Codes

Code	Description
1	Read Coil Status
2	Read Input Status
3	Read Holding Register
4	Read Input Register
5	Force Single Coil
6	Preset Single Register
8	Loopback Diagnostic Command
16	Preset Multiple Registers
17	Read Modbus Address

Modbus Exception Responses

Code	Description
01	Illegal Function Code
02	Illegal Data Address

Data Types

Integer

16-bit signed quantity

Register contains bits 15 - 0 of 16-bit integer

Byte

Two 8-bit unsigned quantities

Bits 15 - 8 of register contain bits 7 - 0 of first 8-bit byte

Bits 7 - 0 of register contain bits 7 - 0 of second 8-bit byte

Floating Point Quantity Format

Intel single precision real (Least significant word first)

First register contains bits 15 - 0 of 32-bit number (bits 15 - 0 of significand)

Second register contains bits 31 - 16 of 32-bit number (exponent and bits 23 - 16 of significand)

Long Integer Quantity Format

32-bit unsigned quantity (Least significant word first)

Bits 15 - 0 of first register = bits 15 - 0 of Long Integer

Bits 15 - 0 of second register = bits 31 - 16 of Long Integer

Valquest Systems, Inc
VAr-Min SR2 Modbus Registers

Discrete Controls (Coils)				Read - FC 1 Write - FC 5					
Index	Addr	Register	Field	Min	Max	Reset	Set		Notes
0	0	00001	Cap Bank Sw itch Trip Sequence			Stop	Start	Binary	No w rite if 00003 = Auto
1	1	00002	Cap Bank Sw itch Close Sequence			Stop	Start	Binary	No w rite if 00003 = Auto
2	2	00003	Operating Mode			Auto	Remote	Binary	
3	3	00004	Voltage w ith Correction Learning			Off	On	Binary	Affects 40023, 40025
4	4	00005	Discharge delay			5 Min	10 Min	Binary	
5	5	00006	Anti-Oscillate Inhibit			Enable	Disable	Binary	
6	6	00007	Return to Auto			Off	On	Binary	
7	7	00008	DNP Clock			Internal	Master	Binary	
16	10	000017	Clear Memory			Events	Trends	Wr Only	Non SCADA Register
17	11	000018	Reset			System	Timers	Wr Only	Non SCADA Register

Binary Inputs				Read - FC 2					
Index	Addr	Register	Field	Min	Max	Reset	Set		Notes
0	0	10001	Cap Bank Sw itch Status			Open	Closed	Binary	
1	1	10002	Cap Bank Sw itch Last Commanded			Open	Closed	Binary	
2	2	10003	Pending Operation			No	Yes	Binary	
3	3	10004	Auto-Manual Sw itch			Auto	Manual	Binary	
4	4	10005	Sw itch Malfuncion			OK	Malfunc	Binary	
5	5	10006	Capacitor Neutral Current			OK	High	Binary	

Instantaneous Readings				Read - FC 4					
Index	Addr	Register	Field	Min	Max	Mpy	Unit		Notes
0	0	30001	VAr-Min firmw are version	200	999	0.01	N/A	Integer	
1	1	30002	VAr-Min firmw are revision	0	999	0.01	N/A	Integer	
2	2	30003	Secondary voltage (1 phase)	0	999.9	1	Volts	Float	Float (2 registers)
4	4	30005	Voltage w ith correction (1 phase)	0	999.9	1	Volts	Float	Float (2 registers)
6	6	30007	Current (1 phase)	0	999	1	Amps	Float	Float (2 registers)
8	8	30009	kW (1 phase x3)	-9999	9999	1	kW	Float	Float (2 registers)
10	A	30011	kVA (1 phase x3)	-9999	9999	1	kVA	Float	Float (2 registers)
12	C	30013	kVA (1 phase x3)	-9999	9999	1	kVA	Float	Float (2 registers)
14	E	30015	Pow er factor (1 phase)	-100	100	1	%	Float	Float (2 registers)
16	10	30017	Phase angle (1 phase)	0	359.9	1	Degrees	Float	Float (2 registers)
18	12	30019	Neutral Current	0	999	1	Amps	Float	Float (2 registers)
20	14	30021	Frequency	0	99.99	1	Hz	Float	Float (2 registers)
22	16	30023	Primary Voltage	0	99999	1	Volts	Float	Float (2 registers)
24	18	30025	Ambient temperature	0	999	1	F	Integer	
25	19	30026	Indoor temperature	0	999	1	F	Integer	
26	1A	30027	Number of sw itch operations	0	2E+9	1	N/A	Long	Long (2 registers)
28	1C	30029	Anti-Oscillate pending timer	0	9999	1	Seconds	Integer	
29	1D	30030	Discharge pending timer	0	999	1	Seconds	Integer	
30	1E	30031	Op-Delay pending timer	0	999	1	Seconds	Integer	

Event Log				Read - FC 4					
Index	Addr	Register	Field	Min	Max	Mpy	Unit		Notes
256	100	30257	Most Recent Record Type	0	15	1	Event	Integer	See Event Codes
257	101	30258	Most Recent Record Date	0	99	1	Years	Integer	
258	102	30259		1	12	1	Months	Integer	
259	103	30260		1	31	1	Days	Integer	
260	104	30261	Most Recent Record Time	0	23	1	Hours	Integer	
261	105	30262		0	59	1	Minutes	Integer	
262	106	30263		0	59	1	Seconds	Integer	
263	107	30264	Most Recent Record - 1 Type	0	15	1	Event	Integer	
264	108	30265	Most Recent Record - 1 Date	0	99	1	Years	Integer	
265	109	30266		1	12	1	Months	Integer	
266	10A	30267		1	31	1	Days	Integer	
267	10B	30268	Most Recent Record - 1 Time	0	23	1	Hours	Integer	
268	10C	30269		0	59	1	Minutes	Integer	
269	10D	30270		0	59	1	Seconds	Integer	
270	10E	30271	Most Recent Record - 2 Type	0	15	1	Event	Integer	
271	10F	30272	Most Recent Record - 2 Date	0	99	1	Years	Integer	
272	110	30273		1	12	1	Months	Integer	
273	111	30274		1	31	1	Days	Integer	
274	112	30275	Most Recent Record - 2 Time	0	23	1	Hours	Integer	
275	113	30276		0	59	1	Minutes	Integer	
276	114	30277		0	59	1	Seconds	Integer	
277	115	30278	Most Recent Record - 3 Type	0	15	1	Event	Integer	
278	116	30279	Most Recent Record - 3 Date	0	99	1	Years	Integer	
279	117	30280		1	12	1	Months	Integer	
280	118	30281		1	31	1	Days	Integer	
281	119	30282	Most Recent Record - 3 Time	0	23	1	Hours	Integer	
282	11A	30283		0	59	1	Minutes	Integer	
283	11B	30284		0	59	1	Seconds	Integer	
284	11C	30285	Most Recent Record - 4 Type	0	15	1	Event	Integer	
285	11D	30286	Most Recent Record - 4 Date	0	99	1	Years	Integer	
286	11E	30287		1	12	1	Months	Integer	
287	11F	30288		1	31	1	Days	Integer	
288	120	30289	Most Recent Record - 4 Time	0	23	1	Hours	Integer	
289	121	30290		0	59	1	Minutes	Integer	
290	122	30291		0	59	1	Seconds	Integer	
291	123	30292	Most Recent Record - 5 Type	0	15	1	Event	Integer	
292	124	30293	Most Recent Record - 5 Date	0	99	1	Years	Integer	
293	125	30294		1	12	1	Months	Integer	
294	126	30295		1	31	1	Days	Integer	
295	127	30296	Most Recent Record - 5 Time	0	23	1	Hours	Integer	
296	128	30297		0	59	1	Minutes	Integer	
297	129	30298		0	59	1	Seconds	Integer	
298	12A	30299	Most Recent Record - 6 Type	0	15	1	Event	Integer	
299	12B	30300	Most Recent Record - 6 Date	0	99	1	Years	Integer	
300	12C	30301		1	12	1	Months	Integer	
301	12D	30302		1	31	1	Days	Integer	
302	12E	30303	Most Recent Record - 6 Time	0	23	1	Hours	Integer	
303	12F	30304		0	59	1	Minutes	Integer	
304	130	30305		0	59	1	Seconds	Integer	
305	131	30306	Most Recent Record - 7 Type	0	15	1	Event	Integer	
306	132	30307	Most Recent Record - 7 Date	0	99	1	Years	Integer	
307	133	30308		1	12	1	Months	Integer	
308	134	30309		1	31	1	Days	Integer	
309	135	30310	Most Recent Record - 7 Time	0	23	1	Hours	Integer	
310	136	30311		0	59	1	Minutes	Integer	
311	137	30312		0	59	1	Seconds	Integer	

Event Log				Read - FC 3					
Index	Addr	Register	Field	Min	Max	Mpy	Unit		Notes
312	138	30313	Most Recent Record - 8 Type	0	15	1	Event	Integer	See Event Codes
313	139	30314	Most Recent Record - 8 Date	0	99	1	Years	Integer	
314	13A	30315		1	12	1	Months	Integer	
315	13B	30316		1	31	1	Days	Integer	
316	13C	30317	Most Recent Record - 8 Time	0	23	1	Hours	Integer	
317	13D	30318		0	59	1	Minutes	Integer	
318	13E	30319		0	59	1	Seconds	Integer	
319	13F	30320	Most Recent Record - 9 Type	0	15	1	Event	Integer	
320	140	30321	Most Recent Record - 9 Date	0	99	1	Years	Integer	
321	141	30322		1	12	1	Months	Integer	
322	142	30323		1	31	1	Days	Integer	
323	143	30324	Most Recent Record - 9 Time	0	23	1	Hours	Integer	
324	144	30325		0	59	1	Minutes	Integer	
325	145	30326		0	59	1	Seconds	Integer	
326	146	30327	Most Recent Record - 10 Type	0	15	1	Event	Integer	
327	147	30328	Most Recent Record - 10 Date	0	99	1	Years	Integer	
328	148	30329		1	12	1	Months	Integer	
329	149	30330		1	31	1	Days	Integer	
330	14A	30331	Most Recent Record - 10 Time	0	23	1	Hours	Integer	
331	14B	30332		0	59	1	Minutes	Integer	
332	14C	30333		0	59	1	Seconds	Integer	
333	14D	30334	Most Recent Record - 11 Type	0	15	1	Event	Integer	
334	14E	30335	Most Recent Record - 11 Date	0	99	1	Years	Integer	
335	14F	30336		1	12	1	Months	Integer	
336	150	30337		1	31	1	Days	Integer	
337	151	30338	Most Recent Record - 11 Time	0	23	1	Hours	Integer	
338	152	30339		0	59	1	Minutes	Integer	
339	153	30340		0	59	1	Seconds	Integer	
340	154	30341	Most Recent Record - 12 Type	0	15	1	Event	Integer	
341	155	30342	Most Recent Record - 12 Date	0	99	1	Years	Integer	
342	156	30343		1	12	1	Months	Integer	
343	157	30344		1	31	1	Days	Integer	
344	158	30345	Most Recent Record - 12 Time	0	23	1	Hours	Integer	
345	159	30346		0	59	1	Minutes	Integer	
346	15A	30347		0	59	1	Seconds	Integer	
347	15B	30348	Most Recent Record - 13 Type	0	15	1	Event	Integer	
348	15C	30349	Most Recent Record - 13 Date	0	99	1	Years	Integer	
349	15D	30350		1	12	1	Months	Integer	
350	15E	30351		1	31	1	Days	Integer	
351	15F	30352	Most Recent Record - 13 Time	0	23	1	Hours	Integer	
352	160	30353		0	59	1	Minutes	Integer	
353	161	30354		0	59	1	Seconds	Integer	
354	162	30355	Most Recent Record - 14 Type	0	15	1	Event	Integer	
355	163	30356	Most Recent Record - 14 Date	0	99	1	Years	Integer	
356	164	30357		1	12	1	Months	Integer	
357	165	30358		1	31	1	Days	Integer	
358	166	30359	Most Recent Record - 14 Time	0	23	1	Hours	Integer	
359	167	30360		0	59	1	Minutes	Integer	
360	168	30361		0	59	1	Seconds	Integer	
361	169	30362	Most Recent Record - 15 Type	0	15	1	Event	Integer	
362	16A	30363	Most Recent Record - 15 Date	0	99	1	Years	Integer	
363	16B	30364		1	12	1	Months	Integer	
364	16C	30365		1	31	1	Days	Integer	
365	16D	30366	Most Recent Record - 15 Time	0	23	1	Hours	Integer	
366	16E	30367		0	59	1	Minutes	Integer	
367	16F	30368		0	59	1	Seconds	Integer	

Event Log				Read - FC 3					
Index	Addr	Register	Field	Min	Max	Mpy	Unit		Notes
368	170	30369	Most Recent Record - 16 Type	0	15	1	Event	Integer	See Event Codes
369	171	30370	Most Recent Record - 16 Date	0	99	1	Years	Integer	
370	172	30371		1	12	1	Months	Integer	
371	173	30372		1	31	1	Days	Integer	
372	174	30373	Most Recent Record - 16 Time	0	23	1	Hours	Integer	
373	175	30374		0	59	1	Minutes	Integer	
374	176	30375		0	59	1	Seconds	Integer	
375	177	30376	Most Recent Record - 17 Type	0	15	1	Event	Integer	
376	178	30377	Most Recent Record - 17 Date	0	99	1	Years	Integer	
377	179	30378		1	12	1	Months	Integer	
378	17A	30379		1	31	1	Days	Integer	
379	17B	30380	Most Recent Record - 17 Time	0	23	1	Hours	Integer	
380	17C	30381		0	59	1	Minutes	Integer	
381	17D	30382		0	59	1	Seconds	Integer	
382	17E	30383	Most Recent Record - 18 Type	0	15	1	Event	Integer	
383	17F	30384	Most Recent Record - 18 Date	0	99	1	Years	Integer	
384	180	30385		1	12	1	Months	Integer	
385	181	30386		1	31	1	Days	Integer	
386	182	30387	Most Recent Record - 18 Time	0	23	1	Hours	Integer	
387	183	30388		0	59	1	Minutes	Integer	
388	184	30389		0	59	1	Seconds	Integer	
389	185	30390	Most Recent Record - 19 Type	0	15	1	Event	Integer	
390	186	30391	Most Recent Record - 19 Date	0	99	1	Years	Integer	
391	187	30392		1	12	1	Months	Integer	
392	188	30393		1	31	1	Days	Integer	
393	189	30394	Most Recent Record - 19 Time	0	23	1	Hours	Integer	
394	18A	30395		0	59	1	Minutes	Integer	
395	18B	30396		0	59	1	Seconds	Integer	
396	18C	30397	Most Recent Record - 20 Type	0	15	1	Event	Integer	
397	18D	30398	Most Recent Record - 20 Date	0	99	1	Years	Integer	
398	18E	30399		1	12	1	Months	Integer	
399	18F	30400		1	31	1	Days	Integer	
400	190	30401	Most Recent Record - 20 Time	0	23	1	Hours	Integer	
401	191	30402		0	59	1	Minutes	Integer	
402	192	30403		0	59	1	Seconds	Integer	
403	193	30404	Most Recent Record - 21 Type	0	15	1	Event	Integer	
404	194	30405	Most Recent Record - 21 Date	0	99	1	Years	Integer	
405	195	30406		1	12	1	Months	Integer	
406	196	30407		1	31	1	Days	Integer	
407	197	30408	Most Recent Record - 21 Time	0	23	1	Hours	Integer	
408	198	30409		0	59	1	Minutes	Integer	
409	199	30410		0	59	1	Seconds	Integer	
410	19A	30411	Most Recent Record - 22 Type	0	15	1	Event	Integer	
411	19B	30412	Most Recent Record - 22 Date	0	99	1	Years	Integer	
412	19C	30413		1	12	1	Months	Integer	
413	19D	30414		1	31	1	Days	Integer	
414	19E	30415	Most Recent Record - 22 Time	0	23	1	Hours	Integer	
415	19F	30416		0	59	1	Minutes	Integer	
416	1A0	30417		0	59	1	Seconds	Integer	
417	1A1	30418	Most Recent Record - 23 Type	0	15	1	Event	Integer	
418	1A2	30419	Most Recent Record - 23 Date	0	99	1	Years	Integer	
419	1A3	30420		1	12	1	Months	Integer	
420	1A4	30421		1	31	1	Days	Integer	
421	1A5	30422	Most Recent Record - 23 Time	0	23	1	Hours	Integer	
422	1A6	30423		0	59	1	Minutes	Integer	
423	1A7	30424		0	59	1	Seconds	Integer	

Event Log				Read - FC 3					
Index	Addr	Register	Field	Min	Max	Mpy	Unit		Notes
424	1A8	30425	Most Recent Record - 24 Type	0	15	1	Event	Integer	See Event Codes
425	1A9	30426	Most Recent Record - 24 Date	0	99	1	Years	Integer	
426	1AA	30427		1	12	1	Months	Integer	
427	1AB	30428		1	31	1	Days	Integer	
428	1AC	30429	Most Recent Record - 24 Time	0	23	1	Hours	Integer	
429	1AD	30430		0	59	1	Minutes	Integer	
430	1AE	30431		0	59	1	Seconds	Integer	
431	1AF	30432	Most Recent Record - 25 Type	0	15	1	Event	Integer	
432	1B0	30433	Most Recent Record - 25 Date	0	99	1	Years	Integer	
433	1B1	30434		1	12	1	Months	Integer	
434	1B2	30435		1	31	1	Days	Integer	
435	1B3	30436	Most Recent Record - 25 Time	0	23	1	Hours	Integer	
436	1B4	30437		0	59	1	Minutes	Integer	
437	1B5	30438		0	59	1	Seconds	Integer	
438	1B6	30439	Most Recent Record - 26 Type	0	15	1	Event	Integer	
439	1B7	30440	Most Recent Record - 26 Date	0	99	1	Years	Integer	
440	1B8	30441		1	12	1	Months	Integer	
441	1B9	30442		1	31	1	Days	Integer	
442	1BA	30443	Most Recent Record - 26 Time	0	23	1	Hours	Integer	
443	1BB	30444		0	59	1	Minutes	Integer	
444	1BC	30445		0	59	1	Seconds	Integer	
445	1BD	30446	Most Recent Record - 27 Type	0	15	1	Event	Integer	
446	1BE	30447	Most Recent Record - 27 Date	0	99	1	Years	Integer	
447	1BF	30448		1	12	1	Months	Integer	
448	1C0	30449		1	31	1	Days	Integer	
449	1C1	30450	Most Recent Record - 27 Time	0	23	1	Hours	Integer	
450	1C2	30451		0	59	1	Minutes	Integer	
451	1C3	30452		0	59	1	Seconds	Integer	
452	1C4	30453	Most Recent Record - 28 Type	0	15	1	Event	Integer	
453	1C5	30454	Most Recent Record - 28 Date	0	99	1	Years	Integer	
454	1C6	30455		1	12	1	Months	Integer	
455	1C7	30456		1	31	1	Days	Integer	
456	1C8	30457	Most Recent Record - 28 Time	0	23	1	Hours	Integer	
457	1C9	30458		0	59	1	Minutes	Integer	
458	1CA	30459		0	59	1	Seconds	Integer	
459	1CB	30460	Most Recent Record - 29 Type	0	15	1	Event	Integer	
460	1CC	30461	Most Recent Record - 29 Date	0	99	1	Years	Integer	
461	1CD	30462		1	12	1	Months	Integer	
462	1CE	30463		1	31	1	Days	Integer	
463	1CF	30464	Most Recent Record - 29 Time	0	23	1	Hours	Integer	
464	1D0	30465		0	59	1	Minutes	Integer	
465	1D1	30466		0	59	1	Seconds	Integer	
466	1D2	30467	Most Recent Record - 30 Type	0	15	1	Event	Integer	
467	1D3	30468	Most Recent Record - 30 Date	0	99	1	Years	Integer	
468	1D4	30469		1	12	1	Months	Integer	
469	1D5	30470		1	31	1	Days	Integer	
470	1D6	30471	Most Recent Record - 30 Time	0	23	1	Hours	Integer	
471	1D7	30472		0	59	1	Minutes	Integer	
472	1D8	30473		0	59	1	Seconds	Integer	
473	1D9	30474	Most Recent Record - 31 Type	0	15	1	Event	Integer	
474	1DA	30475	Most Recent Record - 31 Date	0	99	1	Years	Integer	
475	1DB	30476		1	12	1	Months	Integer	
476	1DC	30477		1	31	1	Days	Integer	
477	1DD	30478	Most Recent Record - 31 Time	0	23	1	Hours	Integer	
478	1DE	30479		0	59	1	Minutes	Integer	
479	1DF	30480		0	59	1	Seconds	Integer	

Historical Page (One Third Day)				Read - FC 3					
Index	Addr	Register	Field	Min	Max	Mpy	Unit		Notes
512	200	30513	Historical Third of Day	0	671	1	N/A	Integer	
513	201	30514	15 Minute Demand - 0	0	999	12	Voltage	Integer	For Companion
514	202	30515		0	255	N/A	Cur-Angle	Byte	Software use only
515	203	30516		0	255	N/A	Stat-Temp	Byte	See User Manual
516	204	30517	15 Minute Demand - 1	0	999	12	Voltage	Integer	
517	205	30518		0	255	N/A	Cur-Angle	Byte	
518	206	30519		0	255	N/A	Stat-Temp	Byte	
519	207	30520	15 Minute Demand - 2	0	999	12	Voltage	Integer	
520	208	30521		0	255	N/A	Cur-Angle	Byte	
521	209	30522		0	255	N/A	Stat-Temp	Byte	
522	20A	30523	15 Minute Demand - 3	0	999	12	Voltage	Integer	
523	20B	30524		0	255	N/A	Cur-Angle	Byte	
524	20C	30525		0	255	N/A	Stat-Temp	Byte	
525	20D	30526	15 Minute Demand - 4	0	999	12	Voltage	Integer	
526	20E	30527		0	255	N/A	Cur-Angle	Byte	
527	20F	30528		0	255	N/A	Stat-Temp	Byte	
528	210	30529	15 Minute Demand - 5	0	999	12	Voltage	Integer	
529	211	30530		0	255	N/A	Cur-Angle	Byte	
530	212	30531		0	255	N/A	Stat-Temp	Byte	
531	213	30532	15 Minute Demand - 6	0	999	12	Voltage	Integer	
532	214	30533		0	255	N/A	Cur-Angle	Byte	
533	215	30534		0	255	N/A	Stat-Temp	Byte	
534	216	30535	15 Minute Demand - 7	0	999	12	Voltage	Integer	
535	217	30536		0	255	N/A	Cur-Angle	Byte	
536	218	30537		0	255	N/A	Stat-Temp	Byte	
537	219	30538	15 Minute Demand - 8	0	999	12	Voltage	Integer	
538	21A	30539		0	255	N/A	Cur-Angle	Byte	
539	21B	30540		0	255	N/A	Stat-Temp	Byte	
540	21C	30541	15 Minute Demand - 9	0	999	12	Voltage	Integer	
541	21D	30542		0	255	N/A	Cur-Angle	Byte	
542	21E	30543		0	255	N/A	Stat-Temp	Byte	
543	21F	30544	15 Minute Demand - 10	0	999	12	Voltage	Integer	
544	220	30545		0	255	N/A	Cur-Angle	Byte	
545	221	30546		0	255	N/A	Stat-Temp	Byte	
546	222	30547	15 Minute Demand - 11	0	999	12	Voltage	Integer	
547	223	30548		0	255	N/A	Cur-Angle	Byte	
548	224	30549		0	255	N/A	Stat-Temp	Byte	
549	225	30550	15 Minute Demand - 12	0	999	12	Voltage	Integer	
550	226	30551		0	255	N/A	Cur-Angle	Byte	
551	227	30552		0	255	N/A	Stat-Temp	Byte	
552	228	30553	15 Minute Demand - 13	0	999	12	Voltage	Integer	
553	229	30554		0	255	N/A	Cur-Angle	Byte	
554	22A	30555		0	255	N/A	Stat-Temp	Byte	
555	22B	30556	15 Minute Demand - 14	0	999	12	Voltage	Integer	
556	22C	30557		0	255	N/A	Cur-Angle	Byte	
557	22D	30558		0	255	N/A	Stat-Temp	Byte	
558	22E	30559	15 Minute Demand - 15	0	999	12	Voltage	Integer	
559	22F	30560		0	255	N/A	Cur-Angle	Byte	
560	230	30561		0	255	N/A	Stat-Temp	Byte	

Historical Page (One Third Day)				Read - FC 3					
Index	Addr	Register	Field	Min	Max	Mpy	Unit		Notes
561	231	30562	15 Minute Demand - 16	0	999	12	Voltage	Integer	
562	232	30563		0	255	N/A	Cur-Angle	Byte	
563	233	30564		0	255	N/A	Stat-Temp	Byte	
564	234	30565	15 Minute Demand - 17	0	999	12	Voltage	Integer	
565	235	30566		0	255	N/A	Cur-Angle	Byte	
566	236	30567		0	255	N/A	Stat-Temp	Byte	
567	237	30568	15 Minute Demand - 18	0	999	12	Voltage	Integer	
568	238	30569		0	255	N/A	Cur-Angle	Byte	
569	239	30570		0	255	N/A	Stat-Temp	Byte	
570	23A	30571	15 Minute Demand - 19	0	999	12	Voltage	Integer	
571	23B	30572		0	255	N/A	Cur-Angle	Byte	
572	23C	30573		0	255	N/A	Stat-Temp	Byte	
573	23D	30574	15 Minute Demand - 20	0	999	12	Voltage	Integer	
574	23E	30575		0	255	N/A	Cur-Angle	Byte	
575	23F	30576		0	255	N/A	Stat-Temp	Byte	
576	240	30577	15 Minute Demand - 21	0	999	12	Voltage	Integer	
577	241	30578		0	255	N/A	Cur-Angle	Byte	
578	242	30579		0	255	N/A	Stat-Temp	Byte	
579	243	30580	15 Minute Demand - 22	0	999	12	Voltage	Integer	
580	244	30581		0	255	N/A	Cur-Angle	Byte	
581	245	30582		0	255	N/A	Stat-Temp	Byte	
582	246	30583	15 Minute Demand - 23	0	999	12	Voltage	Integer	
583	247	30584		0	255	N/A	Cur-Angle	Byte	
584	248	30585		0	255	N/A	Stat-Temp	Byte	
585	249	30586	15 Minute Demand - 24	0	999	12	Voltage	Integer	
586	24A	30587		0	255	N/A	Cur-Angle	Byte	
587	24B	30588		0	255	N/A	Stat-Temp	Byte	
588	24C	30589	15 Minute Demand - 25	0	999	12	Voltage	Integer	
589	24D	30590		0	255	N/A	Cur-Angle	Byte	
590	24E	30591		0	255	N/A	Stat-Temp	Byte	
591	24F	30592	15 Minute Demand - 26	0	999	12	Voltage	Integer	
592	250	30593		0	255	N/A	Cur-Angle	Byte	
593	251	30594		0	255	N/A	Stat-Temp	Byte	
594	252	30595	15 Minute Demand - 27	0	999	12	Voltage	Integer	
595	253	30596		0	255	N/A	Cur-Angle	Byte	
596	254	30597		0	255	N/A	Stat-Temp	Byte	
597	255	30598	15 Minute Demand - 28	0	999	12	Voltage	Integer	
598	256	30599		0	255	N/A	Cur-Angle	Byte	
599	257	30600		0	255	N/A	Stat-Temp	Byte	
600	258	30601	15 Minute Demand - 29	0	999	12	Voltage	Integer	
601	259	30602		0	255	N/A	Cur-Angle	Byte	
602	25A	30603		0	255	N/A	Stat-Temp	Byte	
603	25B	30604	15 Minute Demand - 30	0	999	12	Voltage	Integer	
604	25C	30605		0	255	N/A	Cur-Angle	Byte	
605	25D	30606		0	255	N/A	Stat-Temp	Byte	
606	25E	30607	15 Minute Demand - 31	0	999	12	Voltage	Integer	
607	25F	30608		0	255	N/A	Cur-Angle	Byte	
608	260	30609		0	255	N/A	Stat-Temp	Byte	

Trend Dates				Read - FC 3					
Index	Addr	Register	Field	Min	Max	Mpy	Unit		Notes
640	280	30641	Historical Date - Day 0	101	1231	1	Mo:Day	Integer	For Companion
641	281	30642	Historical Date - Day 1	101	1231	1	Mo:Day	Integer	Softw are use only
642	282	30643	Historical Date - Day 2	101	1231	1	Mo:Day	Integer	See User Manual
643	283	30644	Historical Date - Day 3	101	1231	1	Mo:Day	Integer	
644	284	30645	Historical Date - Day 4	101	1231	1	Mo:Day	Integer	
645	285	30646	Historical Date - Day 5	101	1231	1	Mo:Day	Integer	
646	286	30647	Historical Date - Day 6	101	1231	1	Mo:Day	Integer	
647	287	30648	Historical Date - Day 7	101	1231	1	Mo:Day	Integer	
648	288	30649	Historical Date - Day 8	101	1231	1	Mo:Day	Integer	
649	289	30650	Historical Date - Day 9	101	1231	1	Mo:Day	Integer	
650	28A	30651	Historical Date - Day 10	101	1231	1	Mo:Day	Integer	
651	28B	30652	Historical Date - Day 11	101	1231	1	Mo:Day	Integer	
652	28C	30653	Historical Date - Day 12	101	1231	1	Mo:Day	Integer	
653	28D	30654	Historical Date - Day 13	101	1231	1	Mo:Day	Integer	
654	28E	30655	Historical Date - Day 14	101	1231	1	Mo:Day	Integer	
655	28F	30656	Historical Date - Day 15	101	1231	1	Mo:Day	Integer	
656	290	30657	Historical Date - Day 16	101	1231	1	Mo:Day	Integer	
657	291	30658	Historical Date - Day 17	101	1231	1	Mo:Day	Integer	
658	292	30659	Historical Date - Day 18	101	1231	1	Mo:Day	Integer	
659	293	30660	Historical Date - Day 19	101	1231	1	Mo:Day	Integer	
660	294	30661	Historical Date - Day 20	101	1231	1	Mo:Day	Integer	
661	295	30662	Historical Date - Day 21	101	1231	1	Mo:Day	Integer	
662	296	30663	Historical Date - Day 22	101	1231	1	Mo:Day	Integer	
663	297	30664	Historical Date - Day 23	101	1231	1	Mo:Day	Integer	
664	298	30665	Historical Date - Day 24	101	1231	1	Mo:Day	Integer	
665	299	30666	Historical Date - Day 25	101	1231	1	Mo:Day	Integer	
666	29A	30667	Historical Date - Day 26	101	1231	1	Mo:Day	Integer	
667	29B	30668	Historical Date - Day 27	101	1231	1	Mo:Day	Integer	
668	29C	30669	Historical Date - Day 28	101	1231	1	Mo:Day	Integer	
669	29D	30670	Historical Date - Day 29	101	1231	1	Mo:Day	Integer	
670	29E	30671	Historical Date - Day 30	101	1231	1	Mo:Day	Integer	
671	29F	30672	Historical Date - Day 31	101	1231	1	Mo:Day	Integer	
672	2A0	30673	Historical Date - Day 32	101	1231	1	Mo:Day	Integer	
673	2A1	30674	Historical Date - Day 33	101	1231	1	Mo:Day	Integer	
674	2A2	30675	Historical Date - Day 34	101	1231	1	Mo:Day	Integer	
675	2A3	30676	Historical Date - Day 35	101	1231	1	Mo:Day	Integer	
676	2A4	30677	Historical Date - Day 36	101	1231	1	Mo:Day	Integer	
677	2A5	30678	Historical Date - Day 37	101	1231	1	Mo:Day	Integer	
678	2A6	30679	Historical Date - Day 38	101	1231	1	Mo:Day	Integer	
679	2A7	30680	Historical Date - Day 39	101	1231	1	Mo:Day	Integer	
680	2A8	30681	Historical Date - Day 40	101	1231	1	Mo:Day	Integer	
681	2A9	30682	Historical Date - Day 41	101	1231	1	Mo:Day	Integer	
682	2AA	30683	Historical Date - Day 42	101	1231	1	Mo:Day	Integer	
683	2AB	30684	Historical Date - Day 43	101	1231	1	Mo:Day	Integer	
684	2AC	30685	Historical Date - Day 44	101	1231	1	Mo:Day	Integer	
685	2AD	30686	Historical Date - Day 45	101	1231	1	Mo:Day	Integer	
686	2AE	30687	Historical Date - Day 46	101	1231	1	Mo:Day	Integer	
687	2AF	30688	Historical Date - Day 47	101	1231	1	Mo:Day	Integer	
688	2B0	30689	Historical Date - Day 48	101	1231	1	Mo:Day	Integer	
689	2B1	30690	Historical Date - Day 49	101	1231	1	Mo:Day	Integer	
690	2B2	30691	Historical Date - Day 50	101	1231	1	Mo:Day	Integer	
691	2B3	30692	Historical Date - Day 51	101	1231	1	Mo:Day	Integer	
692	2B4	30693	Historical Date - Day 52	101	1231	1	Mo:Day	Integer	
693	2B5	30694	Historical Date - Day 53	101	1231	1	Mo:Day	Integer	
694	2B6	30695	Historical Date - Day 54	101	1231	1	Mo:Day	Integer	
695	2B7	30696	Historical Date - Day 55	101	1231	1	Mo:Day	Integer	

Trend Dates				Read - FC 3					
Index	Addr	Register	Field	Min	Max	Mpy	Unit		Notes
696	2B8	30697	Historical Date - Day 56	101	1231	1	Mo:Day	Integer	
697	2B9	30698	Historical Date - Day 57	101	1231	1	Mo:Day	Integer	
698	2BA	30699	Historical Date - Day 58	101	1231	1	Mo:Day	Integer	
699	2BB	30700	Historical Date - Day 59	101	1231	1	Mo:Day	Integer	
700	2BC	30701	Historical Date - Day 60	101	1231	1	Mo:Day	Integer	
701	2BD	30702	Historical Date - Day 61	101	1231	1	Mo:Day	Integer	
702	2BE	30703	Historical Date - Day 62	101	1231	1	Mo:Day	Integer	
703	2BF	30704	Historical Date - Day 63	101	1231	1	Mo:Day	Integer	
704	2C0	30705	Historical Date - Day 64	101	1231	1	Mo:Day	Integer	
705	2C1	30706	Historical Date - Day 65	101	1231	1	Mo:Day	Integer	
706	2C2	30707	Historical Date - Day 66	101	1231	1	Mo:Day	Integer	
707	2C3	30708	Historical Date - Day 67	101	1231	1	Mo:Day	Integer	
708	2C4	30709	Historical Date - Day 68	101	1231	1	Mo:Day	Integer	
709	2C5	30710	Historical Date - Day 69	101	1231	1	Mo:Day	Integer	
710	2C6	30711	Historical Date - Day 70	101	1231	1	Mo:Day	Integer	
711	2C7	30712	Historical Date - Day 71	101	1231	1	Mo:Day	Integer	
712	2C8	30713	Historical Date - Day 72	101	1231	1	Mo:Day	Integer	
713	2C9	30714	Historical Date - Day 73	101	1231	1	Mo:Day	Integer	
714	2CA	30715	Historical Date - Day 74	101	1231	1	Mo:Day	Integer	
715	2CB	30716	Historical Date - Day 75	101	1231	1	Mo:Day	Integer	
716	2CC	30717	Historical Date - Day 76	101	1231	1	Mo:Day	Integer	
717	2CD	30718	Historical Date - Day 77	101	1231	1	Mo:Day	Integer	
718	2CE	30719	Historical Date - Day 78	101	1231	1	Mo:Day	Integer	
719	2CF	30720	Historical Date - Day 79	101	1231	1	Mo:Day	Integer	
720	2D0	30721	Historical Date - Day 80	101	1231	1	Mo:Day	Integer	
721	2D1	30722	Historical Date - Day 81	101	1231	1	Mo:Day	Integer	
722	2D2	30723	Historical Date - Day 82	101	1231	1	Mo:Day	Integer	
723	2D3	30724	Historical Date - Day 83	101	1231	1	Mo:Day	Integer	
724	2D4	30725	Historical Date - Day 84	101	1231	1	Mo:Day	Integer	
725	2D5	30726	Historical Date - Day 85	101	1231	1	Mo:Day	Integer	
726	2D6	30727	Historical Date - Day 86	101	1231	1	Mo:Day	Integer	
727	2D7	30728	Historical Date - Day 87	101	1231	1	Mo:Day	Integer	
728	2D8	30729	Historical Date - Day 88	101	1231	1	Mo:Day	Integer	
729	2D9	30730	Historical Date - Day 89	101	1231	1	Mo:Day	Integer	
730	2DA	30731	Historical Date - Day 90	101	1231	1	Mo:Day	Integer	
731	2DB	30732	Historical Date - Day 91	101	1231	1	Mo:Day	Integer	
732	2DC	30733	Historical Date - Day 92	101	1231	1	Mo:Day	Integer	
733	2DD	30734	Historical Date - Day 93	101	1231	1	Mo:Day	Integer	
734	2DE	30735	Historical Date - Day 94	101	1231	1	Mo:Day	Integer	
735	2DF	30736	Historical Date - Day 95	101	1231	1	Mo:Day	Integer	
736	2E0	30737	Historical Date - Day 96	101	1231	1	Mo:Day	Integer	
737	2E1	30738	Historical Date - Day 97	101	1231	1	Mo:Day	Integer	
738	2E2	30739	Historical Date - Day 98	101	1231	1	Mo:Day	Integer	
739	2E3	30740	Historical Date - Day 99	101	1231	1	Mo:Day	Integer	
740	2E4	30741	Historical Date - Day 100	101	1231	1	Mo:Day	Integer	
741	2E5	30742	Historical Date - Day 101	101	1231	1	Mo:Day	Integer	
742	2E6	30743	Historical Date - Day 102	101	1231	1	Mo:Day	Integer	
743	2E7	30744	Historical Date - Day 103	101	1231	1	Mo:Day	Integer	
744	2E8	30745	Historical Date - Day 104	101	1231	1	Mo:Day	Integer	
745	2E9	30746	Historical Date - Day 105	101	1231	1	Mo:Day	Integer	
746	2EA	30747	Historical Date - Day 106	101	1231	1	Mo:Day	Integer	
747	2EB	30748	Historical Date - Day 107	101	1231	1	Mo:Day	Integer	
748	2EC	30749	Historical Date - Day 108	101	1231	1	Mo:Day	Integer	
749	2ED	30750	Historical Date - Day 109	101	1231	1	Mo:Day	Integer	
750	2EE	30751	Historical Date - Day 110	101	1231	1	Mo:Day	Integer	
751	2EF	30752	Historical Date - Day 111	101	1231	1	Mo:Day	Integer	

Date and Time				Read - FC 3 Write - FC 6 or FC 16					
Index	Addr	Register	Field	Min	Max	Mpy	Unit		Notes
0	0	40001	Current Date	0	99	1	Years	Integer	2 digit only
1	1	40002		0	59	1	Months	Integer	
2	2	40003		0	23	1	Days	Integer	
3	3	40004	Current Time	1	31	1	Hours	Integer	
4	4	40005		1	12	1	Minutes	Integer	
5	5	40006		0	99	1	Seconds	Integer	
6	6	40007	Day of the Week	1	7	1	Weekday	Integer	1 = Mon, 7 = Sun

Configuration Settings				Read - FC 3 Write - FC 6 or FC 16					
Index	Addr	Register	Field	Min	Max	Mpy	Unit		Notes
16	10	40017	Unit ID	1	99999	1	N/A	Long	Long (2 registers)
18	12	40019	Voltage Calibration	0.8	1.2	1	N/A	Float	Float (2 registers)
20	14	40021	Current Calibration	0.8	1.2	1	N/A	Float	Float (2 registers)
22	16	40023	VCor Close Delta	0	6	1	Volts	Float	Float (2 registers)
24	18	40025	VCor Open Delta	0	6	1	Volts	Float	Float (2 registers)
26	1A	40027	Sensor Type	0	2	1	N/A	Integer	
27	1B	40028	Power Direction	-1	1	1	N/A	Integer	
28	1C	40029	Line Frequency	50	60	1	Hz	Integer	
29	1D	40030	Voltage-Secondary	120	240	1	Volts	Integer	
30	1E	40031	Delay - Close	0	9999	1	Seconds	Integer	
31	1F	40032	Delay - Open	0	9999	1	Seconds	Integer	
32	20	40033	Delay - Trip (Voltage)	0	255	0.1	Seconds	Integer	
33	21	40034	Delay - Trip (Frequency)	0	255	0.1	Seconds	Integer	
34	22	40035	Current Ratio	0	9999	1	Amps/Volt	Integer	
35	23	40036	Current Phase Shift	0	359	1	Degrees	Integer	
36	24	40037	Temperature Lag Time	0	999	1	Minutes	Integer	
37	25	40038	Cap bank switch - Operate Time	0	30	1	Seconds	Integer	
38	26	40039	Current Gain	0	15	1	N/A	Integer	
39	27	40040	Anti-Osc Time	0	9999	1	Seconds	Integer	
40	28	40041	Anti-Osc Max Number	0	9999	1	Count	Integer	
41	29	40042	Neutral Current CT Ratio	0	9999	1	N/A	Integer	
42	2A	40043	Neutral Current Threshold	0	999	1	Amps	Integer	
43	2B	40044	Switch Sensing	0	3	1	N/A	Integer	1:Trip 2:Close 3:Both
44	2C	40045	Delta V Close Delay Multiplier	0	255	1	Sec/Volt	Integer	
45	2D	40046	Delta V Open delay Multiplier	0	255	1	Sec/Volt	Integer	
46	2E	40047	Voltage - Primary	480	65536	1	Volts	Integer	
47	2F	40048	Neutral Sensor	0	2	1	N/A	Integer	0=None, 1=CT, 2=PT
48	30	40049	Modbus Slave Address	1	254	1	N/A	Integer	
49	31	40050	Modbus Baud Rate	0	7	1	N/A	Integer	0=38.4K, 1=19.2K, etc.
50	32	40051	DNP Slave Address	1	65533	1	N/A	Integer	
51	33	40052	DNP Baud Rate	0	7	1	N/A	Integer	0=38.4K, 1=19.2K, etc.
52	34	40053	Historical Third of Day	0	671	1	N/A	Integer	
53	35	40054	Trend Day	0	224	1	N/A	Integer	

Wizard Settings				Read - FC 3 Write - FC 6 or FC 16					
Index	Addr	Register	Field	Min	Max	Mpy	Unit		Notes
64	40	40065	Control On	0	4	1	N/A	Integer	Changing these settings
65	41	40066	Control With	0	3	1	N/A	Integer	will automatically
66	42	40067	Voltage Underride	0	2800	0.1	Volts	Integer	modify the Algorithm
67	43	40068	Voltage Override	0	2800	0.1	Volts	Integer	settings
68	44	40069	Capacitor Bank Value	0	9999	1	kVAr	Integer	
69	45	40070	Close kVAr	0	9999	1	kVAr	Integer	
70	46	40071	Turn On Time	0	2359	1	Military	Integer	
71	47	40072	Turn Off Time	0	2359	1	Military	Integer	
72	48	40073	Turn Off Temp	0	140	1	Deg F	Integer	
73	49	40074	Turn On Temp	0	140	1	Deg F	Integer	
74	4A	40075	Use Voltage / Frequency Relaying	0	1	1	N/A	Integer	
75	4B	40076	Sensor Position	0	1	1	N/A	Integer	0 = Source side of caps
76	4C	40077	Neutral Sensor	0	2	1	N/A	Integer	0=None, 1=CT, 2=PT

Algorithm Settings - Switches Open				Read - FC 3 Write - FC 6 or FC 16					
Index	Addr	Register	Field	Min	Max	Mpy	Unit		Notes
256	100	40257	Open Step 0 Parameter	0	31	1	N/A	Integer	See Algorithm Codes
257	101	40258	Open Step 0 Condition	0	2	1	N/A	Integer	
258	102	40259	Open Step 0 Value	-32768	32767	1	Variable	Float	Float (2 registers)
260	104	40261	Open Step 0 True Op	0	3	1	N/A	Integer	
261	105	40262	Open Step 0 False Op	0	3	1	N/A	Integer	
262	106	40263	Open Step 1 Parameter	0	31	1	N/A	Integer	
263	107	40264	Open Step 1 Condition	0	2	1	N/A	Integer	
264	108	40265	Open Step 1 Value	-32768	32767	1	Variable	Float	Float (2 registers)
266	10A	40267	Open Step 1 True Op	0	3	1	N/A	Integer	
267	10B	40268	Open Step 1 False Op	0	3	1	N/A	Integer	
268	10C	40269	Open Step 2 Parameter	0	31	1	N/A	Integer	
269	10D	40270	Open Step 2 Condition	0	2	1	N/A	Integer	
270	10E	40271	Open Step 2 Value	-32768	32767	1	Variable	Float	Float (2 registers)
272	110	40273	Open Step 2 True Op	0	3	1	N/A	Integer	
273	111	40274	Open Step 2 False Op	0	3	1	N/A	Integer	
274	112	40275	Open Step 3 Parameter	0	31	1	N/A	Integer	
275	113	40276	Open Step 3 Condition	0	2	1	N/A	Integer	
276	114	40277	Open Step 3 Value	-32768	32767	1	Variable	Float	Float (2 registers)
278	116	40279	Open Step 3 True Op	0	3	1	N/A	Integer	
279	117	40280	Open Step 3 False Op	0	3	1	N/A	Integer	
280	118	40281	Open Step 4 Parameter	0	31	1	N/A	Integer	
281	119	40282	Open Step 4 Condition	0	2	1	N/A	Integer	
282	11A	40283	Open Step 4 Value	-32768	32767	1	Variable	Float	Float (2 registers)
284	11C	40285	Open Step 4 True Op	0	3	1	N/A	Integer	
285	11D	40286	Open Step 4 False Op	0	3	1	N/A	Integer	
286	11E	40287	Open Step 5 Parameter	0	31	1	N/A	Integer	
287	11F	40288	Open Step 5 Condition	0	2	1	N/A	Integer	
288	120	40289	Open Step 5 Value	-32768	32767	1	Variable	Float	Float (2 registers)
290	122	40291	Open Step 5 True Op	0	3	1	N/A	Integer	
291	123	40292	Open Step 5 False Op	0	3	1	N/A	Integer	
292	124	40293	Open Step 6 Parameter	0	31	1	N/A	Integer	
293	125	40294	Open Step 6 Condition	0	2	1	N/A	Integer	
294	126	40295	Open Step 6 Value	-32768	32767	1	Variable	Float	Float (2 registers)
296	128	40297	Open Step 6 True Op	0	3	1	N/A	Integer	
297	129	40298	Open Step 6 False Op	0	3	1	N/A	Integer	
298	12A	40299	Open Step 7 Parameter	0	31	1	N/A	Integer	
299	12B	40300	Open Step 7 Condition	0	2	1	N/A	Integer	
300	12C	40301	Open Step 7 Value	-32768	32767	1	Variable	Float	Float (2 registers)
302	12E	40303	Open Step 7 True Op	0	3	1	N/A	Integer	
303	12F	40304	Open Step 7 False Op	0	3	1	N/A	Integer	
304	130	40305	Open Step 8 Parameter	0	31	1	N/A	Integer	
305	131	40306	Open Step 8 Condition	0	2	1	N/A	Integer	
306	132	40307	Open Step 8 Value	-32768	32767	1	Variable	Float	Float (2 registers)
308	134	40309	Open Step 8 True Op	0	3	1	N/A	Integer	
309	135	40310	Open Step 8 False Op	0	3	1	N/A	Integer	
310	136	40311	Open Step 9 Parameter	0	31	1	N/A	Integer	
311	137	40312	Open Step 9 Condition	0	2	1	N/A	Integer	
312	138	40313	Open Step 9 Value	-32768	32767	1	Variable	Float	Float (2 registers)
314	13A	40315	Open Step 9 True Op	0	3	1	N/A	Integer	
315	13B	40316	Open Step 9 False Op	0	3	1	N/A	Integer	

Algorithm - Switches Closed				Read - FC 3 Write - FC 6 or FC 16					
Index	Addr	Register	Field	Min	Max	Mpy	Unit		Notes
316	13C	40317	Closed Step 0 Parameter	0	31	1	N/A	Integer	See Algorithm Codes
317	13D	40318	Closed Step 0 Condition	0	2	1	N/A	Integer	
318	13E	40319	Closed Step 0 Value	-32768	32767	1	Variable	Float	Float (2 registers)
320	140	40321	Closed Step 0 True Op	0	4	1	N/A	Integer	
321	141	40322	Closed Step 0 False Op	0	3	1	N/A	Integer	
322	142	40323	Closed Step 1 Parameter	0	31	1	N/A	Integer	
323	143	40324	Closed Step 1 Condition	0	2	1	N/A	Integer	
324	144	40325	Closed Step 1 Value	-32768	32767	1	Variable	Float	Float (2 registers)
326	146	40327	Closed Step 1 True Op	0	4	1	N/A	Integer	
327	147	40328	Closed Step 1 False Op	0	3	1	N/A	Integer	
328	148	40329	Closed Step 2 Parameter	0	31	1	N/A	Integer	
329	149	40330	Closed Step 2 Condition	0	2	1	N/A	Integer	
330	14A	40331	Closed Step 2 Value	-32768	32767	1	Variable	Float	Float (2 registers)
332	14C	40333	Closed Step 2 True Op	0	4	1	N/A	Integer	
333	14D	40334	Closed Step 2 False Op	0	3	1	N/A	Integer	
334	14E	40335	Closed Step 3 Parameter	0	31	1	N/A	Integer	
335	14F	40336	Closed Step 3 Condition	0	2	1	N/A	Integer	
336	150	40337	Closed Step 3 Value	-32768	32767	1	Variable	Float	Float (2 registers)
338	152	40339	Closed Step 3 True Op	0	4	1	N/A	Integer	
339	153	40340	Closed Step 3 False Op	0	3	1	N/A	Integer	
340	154	40341	Closed Step 4 Parameter	0	31	1	N/A	Integer	
341	155	40342	Closed Step 4 Condition	0	2	1	N/A	Integer	
342	156	40343	Closed Step 4 Value	-32768	32767	1	Variable	Float	Float (2 registers)
344	158	40345	Closed Step 4 True Op	0	4	1	N/A	Integer	
345	159	40346	Closed Step 4 False Op	0	3	1	N/A	Integer	
346	15A	40347	Closed Step 5 Parameter	0	31	1	N/A	Integer	
347	15B	40348	Closed Step 5 Condition	0	2	1	N/A	Integer	
348	15C	40349	Closed Step 5 Value	-32768	32767	1	Variable	Float	Float (2 registers)
350	15E	40351	Closed Step 5 True Op	0	4	1	N/A	Integer	
351	15F	40352	Closed Step 5 False Op	0	3	1	N/A	Integer	
352	160	40353	Closed Step 6 Parameter	0	31	1	N/A	Integer	
353	161	40354	Closed Step 6 Condition	0	2	1	N/A	Integer	
354	162	40355	Closed Step 6 Value	-32768	32767	1	Variable	Float	Float (2 registers)
356	164	40357	Closed Step 6 True Op	0	4	1	N/A	Integer	
357	165	40358	Closed Step 6 False Op	0	3	1	N/A	Integer	
358	166	40359	Closed Step 7 Parameter	0	31	1	N/A	Integer	
359	167	40360	Closed Step 7 Condition	0	2	1	N/A	Integer	
360	168	40361	Closed Step 7 Value	-32768	32767	1	Variable	Float	Float (2 registers)
362	16A	40363	Closed Step 7 True Op	0	4	1	N/A	Integer	
363	16B	40364	Closed Step 7 False Op	0	3	1	N/A	Integer	
364	16C	40365	Closed Step 8 Parameter	0	31	1	N/A	Integer	
365	16D	40366	Closed Step 8 Condition	0	2	1	N/A	Integer	
366	16E	40367	Closed Step 8 Value	-32768	32767	1	Variable	Float	Float (2 registers)
368	170	40369	Closed Step 8 True Op	0	4	1	N/A	Integer	
369	171	40370	Closed Step 8 False Op	0	3	1	N/A	Integer	
370	172	40371	Closed Step 9 Parameter	0	31	1	N/A	Integer	
371	173	40372	Closed Step 9 Condition	0	2	1	N/A	Integer	
372	174	40373	Closed Step 9 Value	-32768	32767	1	Variable	Float	Float (2 registers)
374	176	40375	Closed Step 9 True Op	0	4	1	N/A	Integer	
375	177	40376	Closed Step 9 False Op	0	3	1	N/A	Integer	

Holiday Definitions				Read - FC 3 Write - FC 6 or FC 16					
Index	Addr	Register	Field	Min	Max	Mpy	Unit		Notes
512	200	40513	Holiday - 0	0	255	1	Yr - Mo	Byte	For Companion
513	201	40514		0	255		Day - Wk	Byte	Softw are use only
514	202	40515	Holiday - 1	0	255	1	Yr - Mo	Byte	See User Manual
515	203	40516		0	255		Day - Wk	Byte	
516	204	40517	Holiday - 2	0	255	1	Yr - Mo	Byte	
517	205	40518		0	255		Day - Wk	Byte	
518	206	40519	Holiday - 3	0	255	1	Yr - Mo	Byte	
519	207	40520		0	255		Day - Wk	Byte	
520	208	40521	Holiday - 4	0	255	1	Yr - Mo	Byte	
521	209	40522		0	255		Day - Wk	Byte	
522	20A	40523	Holiday - 5	0	255	1	Yr - Mo	Byte	
523	20B	40524		0	255		Day - Wk	Byte	
524	20C	40525	Holiday - 6	0	255	1	Yr - Mo	Byte	
525	20D	40526		0	255		Day - Wk	Byte	
526	20E	40527	Holiday - 7	0	255	1	Yr - Mo	Byte	
527	20F	40528		0	255		Day - Wk	Byte	
528	210	40529	Holiday - 8	0	255	1	Yr - Mo	Byte	
529	211	40530		0	255		Day - Wk	Byte	
530	212	40531	Holiday - 9	0	255	1	Yr - Mo	Byte	
531	213	40532		0	255		Day - Wk	Byte	
532	214	40533	Holiday - 10	0	255	1	Yr - Mo	Byte	
533	215	40534		0	255		Day - Wk	Byte	
534	216	40535	Holiday - 11	0	255	1	Yr - Mo	Byte	
535	217	40536		0	255		Day - Wk	Byte	
536	218	40537	Holiday - 12	0	255	1	Yr - Mo	Byte	
537	219	40538		0	255		Day - Wk	Byte	
538	21A	40539	Holiday - 13	0	255	1	Yr - Mo	Byte	
539	21B	40540		0	255		Day - Wk	Byte	
540	21C	40541	Holiday - 14	0	255	1	Yr - Mo	Byte	
541	21D	40542		0	255		Day - Wk	Byte	
542	21E	40543	Holiday - 15	0	255	1	Yr - Mo	Byte	
543	21F	40544		0	255		Day - Wk	Byte	
544	220	40545	Holiday - 16	0	255	1	Yr - Mo	Byte	
545	221	40546		0	255		Day - Wk	Byte	
546	222	40547	Holiday - 17	0	255	1	Yr - Mo	Byte	
547	223	40548		0	255		Day - Wk	Byte	
548	224	40549	Holiday - 18	0	255	1	Yr - Mo	Byte	
549	225	40550		0	255		Day - Wk	Byte	
550	226	40551	Holiday - 19	0	255	1	Yr - Mo	Byte	
551	227	40552		0	255		Day - Wk	Byte	
552	228	40553	Holiday - 20	0	255	1	Yr - Mo	Byte	
553	229	40554		0	255		Day - Wk	Byte	
554	22A	40555	Holiday - 21	0	255	1	Yr - Mo	Byte	
555	22B	40556		0	255		Day - Wk	Byte	
556	22C	40557	Holiday - 22	0	255	1	Yr - Mo	Byte	
557	22D	40558		0	255		Day - Wk	Byte	
558	22E	40559	Holiday - 23	0	255	1	Yr - Mo	Byte	
559	22F	40560		0	255		Day - Wk	Byte	
560	230	40561	Holiday - 24	0	255	1	Yr - Mo	Byte	
561	231	40562		0	255		Day - Wk	Byte	

Holiday Definitions				Read - FC 3 Write - FC 6 or FC 16					
Index	Addr	Register	Field	Min	Max	Mpy	Unit		Notes
562	232	40563	Holiday - 25	0	255	1	Yr - Mo	Byte	
563	233	40564		0	255		Day - Wk	Byte	
564	234	40565	Holiday - 26	0	255	1	Yr - Mo	Byte	
565	235	40566		0	255		Day - Wk	Byte	
566	236	40567	Holiday - 27	0	255	1	Yr - Mo	Byte	
567	237	40568		0	255		Day - Wk	Byte	
568	238	40569	Holiday - 28	0	255	1	Yr - Mo	Byte	
569	239	40570		0	255		Day - Wk	Byte	
570	23A	40571	Holiday - 29	0	255	1	Yr - Mo	Byte	
571	23B	40572		0	255		Day - Wk	Byte	
572	23C	40573	Holiday - 30	0	255	1	Yr - Mo	Byte	
573	23D	40574		0	255		Day - Wk	Byte	
574	23E	40575	Holiday - 31	0	255	1	Yr - Mo	Byte	
575	23F	40576		0	255		Day - Wk	Byte	
576	240	40577	Holiday - 32	0	255	1	Yr - Mo	Byte	
577	241	40578		0	255		Day - Wk	Byte	
578	242	40579	Holiday - 33	0	255	1	Yr - Mo	Byte	
579	243	40580		0	255		Day - Wk	Byte	
580	244	40581	Holiday - 34	0	255	1	Yr - Mo	Byte	
581	245	40582		0	255		Day - Wk	Byte	
582	246	40583	Holiday - 35	0	255	1	Yr - Mo	Byte	
583	247	40584		0	255		Day - Wk	Byte	
584	248	40585	Holiday - 36	0	255	1	Yr - Mo	Byte	
585	249	40586		0	255		Day - Wk	Byte	
586	24A	40587	Holiday - 37	0	255	1	Yr - Mo	Byte	
587	24B	40588		0	255		Day - Wk	Byte	
588	24C	40589	Holiday - 38	0	255	1	Yr - Mo	Byte	
589	24D	40590		0	255		Day - Wk	Byte	
590	24E	40591	Holiday - 39	0	255	1	Yr - Mo	Byte	
591	24F	40592		0	255		Day - Wk	Byte	
592	250	40593	Holiday - 40	0	255	1	Yr - Mo	Byte	
593	251	40594		0	255		Day - Wk	Byte	
594	252	40595	Holiday - 41	0	255	1	Yr - Mo	Byte	
595	253	40596		0	255		Day - Wk	Byte	
596	254	40597	Holiday - 42	0	255	1	Yr - Mo	Byte	
597	255	40598		0	255		Day - Wk	Byte	
598	256	40599	Holiday - 43	0	255	1	Yr - Mo	Byte	
599	257	40600		0	255		Day - Wk	Byte	
600	258	40601	Holiday - 44	0	255	1	Yr - Mo	Byte	
601	259	40602		0	255		Day - Wk	Byte	
602	25A	40603	Holiday - 45	0	255	1	Yr - Mo	Byte	
603	25B	40604		0	255		Day - Wk	Byte	
604	25C	40605	Holiday - 46	0	255	1	Yr - Mo	Byte	
605	25D	40606		0	255		Day - Wk	Byte	
606	25E	40607	Holiday - 47	0	255	1	Yr - Mo	Byte	
607	25F	40608		0	255		Day - Wk	Byte	
608	260	40609	Holiday - 48	0	255	1	Yr - Mo	Byte	
609	261	40610		0	255		Day - Wk	Byte	
610	262	40611	Holiday - 49	0	255	1	Yr - Mo	Byte	
611	263	40612		0	255		Day - Wk	Byte	

DNP Deadbands

Index	Addr	Register	Field	Min	Max	Mpy	Unit		Notes
640	280	40641	Secondary voltage (1 phase)	0	32767	0.1	Volts	Integer	
641	281	40642	Voltage with correction (1 phase)	0	32767	0.1	Volts	Integer	
642	282	40643	Current (1 phase)	0	32767	1	Amps	Integer	
643	283	40644	kW (1 phase x3)	0	32767	1	kW	Integer	
644	284	40645	kVA (1 phase x3)	0	32767	1	kVA	Integer	
645	285	40646	kVAr (1 phase x3)	0	32767	1	kVAr	Integer	
646	286	40647	Power factor (1 phase)	0	32767	0.1	%	Integer	
647	287	40648	Phase angle (1 phase)	0	32767	1	Degrees	Integer	
648	288	40649	Neutral Current	0	32767	1	Amps	Integer	
649	289	40650	Frequency	0	32767	0.01	Hz	Integer	
650	28A	40651	Ambient temperature	0	32767	1	F	Integer	
651	28B	40652	Indoor temperature	0	32767	1	F	Integer	
652	28C	40653	Number of switch operations	0	32767	1	Full Cycle	Integer	

DNP Analog Input Map

Index	Addr	Register	Field	Min	Max	Default	Unit		Notes
672	2A0	40673	DNP Analog Input Index 0	-1	31	0	N/A	Integer	
673	2A1	40674	DNP Analog Input Index 1	-1	31	1	N/A	Integer	
674	2A2	40675	DNP Analog Input Index 2	-1	31	2	N/A	Integer	
675	2A3	40676	DNP Analog Input Index 3	-1	31	3	N/A	Integer	
676	2A4	40677	DNP Analog Input Index 4	-1	31	4	N/A	Integer	
677	2A5	40678	DNP Analog Input Index 5	-1	31	5	N/A	Integer	
678	2A6	40679	DNP Analog Input Index 6	-1	31	6	N/A	Integer	
679	2A7	40680	DNP Analog Input Index 7	-1	31	7	N/A	Integer	
680	2A8	40681	DNP Analog Input Index 8	-1	31	8	N/A	Integer	
681	2A9	40682	DNP Analog Input Index 9	-1	31	9	N/A	Integer	
682	2AA	40683	DNP Analog Input Index 10	-1	31	10	N/A	Integer	
683	2AB	40684	DNP Analog Input Index 11	-1	31	11	N/A	Integer	
684	2AC	40685	DNP Analog Input Index 12	-1	31	12	N/A	Integer	
685	2AD	40686	DNP Analog Input Index 13	-1	31	13	N/A	Integer	
686	2AE	40687	DNP Analog Input Index 14	-1	31	14	N/A	Integer	
687	2AF	40688	DNP Analog Input Index 15	-1	31	15	N/A	Integer	
688	2B0	40689	DNP Analog Input Index 16	-1	31	16	N/A	Integer	
689	2B1	40690	DNP Analog Input Index 17	-1	31	-1	N/A	Integer	
690	2B2	40691	DNP Analog Input Index 18	-1	31	-1	N/A	Integer	
691	2B3	40692	DNP Analog Input Index 19	-1	31	-1	N/A	Integer	
692	2B4	40693	DNP Analog Input Index 20	-1	31	-1	N/A	Integer	
693	2B5	40694	DNP Analog Input Index 21	-1	31	-1	N/A	Integer	
694	2B6	40695	DNP Analog Input Index 22	-1	31	-1	N/A	Integer	
695	2B7	40696	DNP Analog Input Index 23	-1	31	-1	N/A	Integer	

DNP Binary Input Map

Index	Addr	Register	Field	Min	Max	Default	Unit		Notes
704	2C0	40705	DNP Binary Input Index 0	-1	31	0	N/A	Integer	
705	2C1	40706	DNP Binary Input Index 1	-1	31	1	N/A	Integer	
706	2C2	40707	DNP Binary Input Index 2	-1	31	2	N/A	Integer	
707	2C3	40708	DNP Binary Input Index 3	-1	31	3	N/A	Integer	
708	2C4	40709	DNP Binary Input Index 4	-1	31	4	N/A	Integer	
709	2C5	40710	DNP Binary Input Index 5	-1	31	5	N/A	Integer	
710	2C6	40711	DNP Binary Input Index 6	-1	31	6	N/A	Integer	
711	2C7	40712	DNP Binary Input Index 7	-1	31	7	N/A	Integer	
712	2C8	40713	DNP Binary Input Index 8	-1	31	-1	N/A	Integer	
713	2C9	40714	DNP Binary Input Index 9	-1	31	-1	N/A	Integer	
714	2CA	40715	DNP Binary Input Index 10	-1	31	-1	N/A	Integer	
715	2CB	40716	DNP Binary Input Index 11	-1	31	-1	N/A	Integer	
716	2CC	40717	DNP Binary Input Index 12	-1	31	-1	N/A	Integer	
717	2CD	40718	DNP Binary Input Index 13	-1	31	-1	N/A	Integer	
718	2CE	40719	DNP Binary Input Index 14	-1	31	-1	N/A	Integer	
719	2CF	40720	DNP Binary Input Index 15	-1	31	-1	N/A	Integer	

Algorithm Codes

Algorithm Step Parameters				All expressed as Float (2 registers)			
		Code	Parameter	Min	Max	Mpy	Unit
		0	Voltage	0	999.9	1	Volts
		1	Current	0	999.9	1	Amps
		2	Power	-32768	32767	1	kW
		3	Reactive Power	-32768	32767	1	kVAr
		4	Frequency	0	99.99	1	Hz
		5	Temperature	0	999	1	Degrees
		6	Date	101	1231	0.01	MM.DD
		7	Time	0	2359	0.01	HH.MM
		8	Day of Week	1	7	1	Mon--Sun
		9	Voltage with Correction	0	999.9	1	Volts

Algorithm Step Conditions						
		Code	Condition			Symbol
		0	Is greater than			>
		1	Is less than			<
		2	Is equal to			=

Algorithm Closed Step True Operation Directives						
		Code	Op Directive			Symbol
		0	Open Switches after Delay			O
		1	Switches Stay Closed			C
		2	Go to Next Step			N
		3	Skip Next Step			S
		4	Trip Switches Immediately (Fast Trip)			T

Algorithm Closed Step False Operation Directives						
		Code	Op Directive			Symbol
		0	Open Switches after Delay			O
		1	Switches Stay Closed			C
		2	Go to Next Step			N
		3	Skip Next Step			S

Algorithm Open Step True / False Operation Directives						
		Code	Op Directive			Symbol
		0	Switches Stay Open			O
		1	Close Switches after Delay			C
		2	Go to Next Step			N
		3	Skip Next Step			S

Event Code Description

Parameters in Most Significant Nibble						
	Code	MSN	Parameter	Min	Max	Unit
	0X	0	Voltage	5	14	Volts
	1X	1	Current	21	30	Amps
	2X	2	Power	37	46	kW
	3X	3	Reactive Power	53	62	kVAr
	4X	4	Frequency	69	78	Hz
	5X	5	Temperature	85	94	Degrees
	6X	6	Date	101	110	MM.DD
	7X	7	Time	117	126	HH.MM
	8X	8	Day of Week	133	142	Mon--Sun
	9X	9	Voltage with Correction	149	158	Volts
	AX	10	Reserved			
	BX	11	Reserved			
	CX	12	External	193	194	N/A
	DX	13	SCADA	209	210	N/A
	EX	14	Malfunction	225	226	N/A
	FX	15	Manual	241	242	N/A

Operation in Least Significant Nibble			
	Code	LSN	Operation
	X0	0	Close for Cause 12-15
	X1	1	Open for Cause 12-15
	X2	2	Failed to Close for Cause 12-15
	X3	3	Failed to Open for Cause 12-15
	X4	4	Close - Measured Value > Parameter
	X5	5	Open - Measured Value > Parameter
	X6	6	Failed to Close - Value > Parameter
	X7	7	Failed to Open - Value > Parameter
	X8	8	Close - Measured Value < Parameter
	X9	9	Open - Measured Value < Parameter
	XA	10	Failed to Close - Value < Parameter
	XB	11	Failed to Open - Value < Parameter
	XC	12	Close - Measured Value = Parameter
	XD	13	Open - Measured Value = Parameter
	XE	14	Failed to Close - Value = Parameter
	XF	15	Failed to Open - Value = Parameter

Valquest Systems, Inc.
 351 S. Sherman Ste. 100
 Richardson, Texas 75081
 972-234-2954
 972-238-9501 Fax
 www.valquest.net

Var-Min SR3 DNP 3.0 Protocol Device Profile Data Dictionary

October 22, 2019 v 1.03 Database v1

THE INFORMATION CONTAINED IN THIS DOCUMENT IS THE PROPERTY OF VALQUEST SYSTEMS, INC.
UNAUTHORIZED REPRODUCTION OR MODIFICATION IS PROHIBITED.

<u>Document</u>	<u>Date</u>	<u>Database</u>	<u>Description</u>
1.01	5/2/2007	v1	Initial release.
1.02	5/5/2008	v1	Added Return-to-Auto in Binary Inputs and Control Outputs
1.03	10/22/2019	v1	Corrected for new parameters

VAr-Min SR3 DNP 3.0 Device Profile Data Dictionary

INPUT SUBSYSTEM									
Binary Inputs									
Default Static Variation					Default Event Variation				
Obj 01 Var 01 Binary w/o status					Obj 02 Var 02 Binary with time				
Description	Index	Class			Index	Class			Class
Cap bank switch Closed / Open	Set / Rst	00	0						1
Remote / Auto Mode	Set / Rst	01	0						1
Voltage with Correction Learning Enab / Disab	Set / Rst	02	0						1
Fuse Check (Blown / OK)	Set / Rst	03	0						1
Anti-Oscillate Disabled / Enabled	Set / Rst	04	0						1
Auto-Manual switch = Manual / Auto	Set / Rst	05	0	Sets IIN Local					1
Switch / Cable Malfuction Lockout / OK	Set / Rst	06	0						1
Return to Auto Disabled / Enabled	Set / Rst	07	0						1
Cap Discharge Delay = 10 / 5 Minutes	Set / Rst	08	0						1
Blown Fuse Lockout / OK	Set / Rst	09	0						1
Algorithm Oscillation Lockout / OK	Set / Rst	10	0						1
Blown Fuse Lockout Disabled / Enabled	Set / Rst	11	0						1

OUTPUT SUBSYSTEM - Control Output Block Operations and Status											
Binary Outputs		Default Variation		Obj 12 Var 01		Binary in response bit Index		Default Condition		Conditions to Operate	
Description	Index	Operation Type	On / Off	On / Off	On / Off	On / Off	On / Off	On / Off	On / Off	On / Off	Binary Input 1 (Remote Mode) must be Set
Cap bank switch Close / Open Sequence	00	Latched	On / Off	On / Off	On / Off	On / Off	On / Off	00	Off	Off	Binary Input 1 (Remote Mode) must be Set
Remote Mode / Auto Mode	01	Latched	On / Off	On / Off	On / Off	On / Off	On / Off	01	Off	Off	
Voltage with Correction Learning Enable / Disable	02	Latched	On / Off	On / Off	On / Off	On / Off	On / Off	02	On	On	
Cap Discharge Delay = 10 / 5 Minutes	03	Latched	On / Off	On / Off	On / Off	On / Off	On / Off	08	Off	Off	
Anti-Oscillate Disable / Enable	04	Latched	On / Off	On / Off	On / Off	On / Off	On / Off	04	Off	Off	
Return-to-Auto Enable / Disable	05	Latched	On / Off	On / Off	On / Off	On / Off	On / Off	07	Off	Off	
Lockout Reset	06	Pulsed	On	On	On	On	On	06, 09, 10	Off	Off	Clears all Binary Input Lockout Bits
Blown Fuse Lockout Disable / Enable	07	Latched	On / Off	On / Off	On / Off	On / Off	On / Off	11	Off	Off	

Note: Binary Input 5 (Local) must be Off for all Binary Output Functions
 This means the Cap Control must not be in Manual Mode

VAR-Min SR3 DNP 3.0 Device Profile Data Dictionary

Analog Inputs	Default Static Variation			Default Event Variation		
	Obj 30	Var 04	16 bit	Obj 32	Var 02	16 bit w/o time
Description	Index	Class	Scale Factor	Units	Class	
Secondary voltage (1 phase)	0	0	0.1	Volts	2	
Voltage with correction (1 phase)	1	0	0.1	Volts	2	
Current (1 phase)	2	0	1	Amps	2	
kW (1 phase x3)	3	0	1	kW	2	
kVAR (1 phase x3)	4	0	1	kVAR	2	
kVA (1 phase x3)	5	0	1	kVA	2	
Power factor (1 phase)	6	0	0.1	%	2	
Phase angle (1 phase)	7	0	1	Degrees	2	
Cap Neutral Current	8	0	1	Amps	2	
Frequency	9	0	0.01	Hz	2	
Ambient temperature	10	0	1	F	2	
Indoor temperature	11	0	1	F	2	
Number of switch operations	12	0	1	Trips	2	
Op-Delay pending timer	13	0	1	Seconds	-	
Anti-Oscillate pending timer	14	0	1	Seconds	-	
Discharge pending timer	15	0	1	Seconds	-	
Var-Min firmware version	16	-	1	x.xx	-	

INPUT SUBSYSTEM - Write Output Blocks						
Deadbands for Analog Inputs						
<i>(Using Analog Outputs)</i>						
Description	Index	Default	Scale Factor	Units	Class	
Secondary voltage (1 phase)	0	5.0	0.1	Volts	2	
Voltage with correction (1 phase)	1	5.0	0.1	Volts	2	
Current (1 phase)	2	50	1	Amps	2	
kW (1 phase x3)	3	500	1	kW	2	
kVAR (1 phase x3)	4	500	1	kVAR	2	
kVA (1 phase x3)	5	500	1	kVA	2	
Power factor (1 phase)	6	10.0%	0.1	%	2	
Phase angle (1 phase)	7	20	1	Degrees	2	
Cap Neutral Current	8	4	1	Amps	2	
Frequency	9	0.1	0.01	Hz	2	
Ambient temperature	10	20	1	F	2	
Indoor temperature	11	20	1	F	2	
Number of switch operations	12	1	1	Full Cycle	2	

Valquest Systems, Inc.
401 S. Sherman, Suite 303
Richardson, Texas 75081
Phone: 972-234-2954
Fax: 972-238-9501